

Commercial Door Operators

TROUBLESHOOTING GUIDE

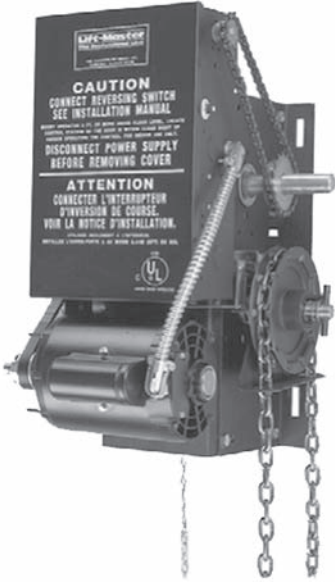
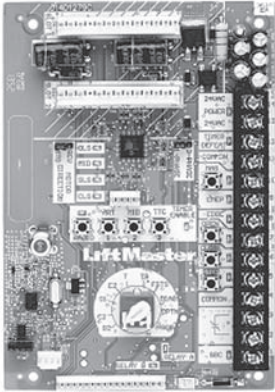

LiftMaster®

EFFECTIVE OCTOBER 2014

General Information

This guide is intended to help with Commercial Door Operator maintenance and troubleshooting. The guide offers several different troubleshooting scenarios and provides answers to frequently asked questions. The comprehensive, yet user-friendly guide will hopefully be used as a tool to solve all of the Commercial Door Operator maintenance problems you may encounter.

SECTION A

Basic Troubleshooting

4-5

SECTION B

Logic Operators

Industrial Duty Logic Operators

8-26

Medium Duty Logic Operators

27-31

SECTION C

Mechanical Operators

34-36

SECTION D

Basic Electrical Information

38-44

SECTION E

General Information

46-51

SECTION F

Wiring Diagrams

54-62

Commercial Door Entrapment Protection Systems

63

Table of Contents

SECTION A

	Page
Basic Troubleshooting	4

Basic Troubleshooting

Always Follow Local Electrical Codes

WARNING! If you are not trained in electrical safety, contact a professional electrical safety trainer. It is in your best interest to have electrical safety training. Do not attempt to work on a powered (turned on) operator if you have not received electrical safety training. Remember, it is dangerous to deal with high-voltage electricity. Many people incurred serious injuries, including fatalities, as a result of electrical accidents. You must be very careful when checking line voltages.

The high-voltage wiring to the operator, low-voltage wiring to the control station(s), and safety devices may require a licensed electrician for installation.

Make Sure The Door Is Working Properly

Close the door and disconnect the door from the operator. Manually operate the door. The lifting force needed by most doors should be manageable by one person and the door should move smoothly. Check all hardware for wear, binding and tightness. Replace any marginal parts. The door should be in good working order. An unbalanced or jerking door will put excess wear on the operator and cause premature failure. When checking a door with a hoist operator, be sure the door is disconnected from the operator and lifted by hand and not by the hoist/hand chain. It is very difficult to determine if the door is balanced when using the operator chain hoist. Repair any door problems before reattaching the operator.

Remove All Accessories And Control Devices

In many cases an operator may be malfunctioning due to accessories or control devices attached to the operator's control circuit. The first step in troubleshooting is to use a process of elimination. Disconnect all wired accessories and control devices. Many times in complicated installations, there will be extra devices installed by an electrician or other subcontractor that may not be functioning properly with the operator. If the door functions properly after disconnecting additional devices, start reconnecting each device one at a time. Determine if any of the control device(s) are causing the problem. Advise the customer of your findings and their options for repairs/replacements.

Check Incoming Voltage

Check the incoming power voltage to ensure readings are within 10% of the rated voltage. For example, a 115VAC-rated power line should read between 103.5 to 126.5VAC. Continue to monitor voltage as the operator is activated through one cycle. Voltage may drop, but should not drop more than two to three volts lower than at the non-functioning position. Low voltage can cause damage to components and cause functionality issues.

Check The Overload

Look at the overload button (when present) on the outside or inside of the electrical box. To confirm if the overload has been tripped, press the overload button. If the overload has been tripped, look for a short or bad wire in the operator. Resetting the overload will only fix the problem temporarily. LiftMaster recommends the cause of the overload be identified and resolved. Logic operators are equipped with a thermal overload and will automatically reset themselves. After the operator cools it must be run a full cycle.

Check Any Interlock Switches

Check any interlock and/or disconnect switches for full activation. Manually activate any interlock switches to verify proper motion of the switch and use a multimeter across the switch leads to verify proper electrical output. The output should show a closed circuit (low resistance) when the door is ready to be activated.

All of the above testing is generic for Logic 3.0, Logic 4.0, Logic 5.0, Medium Duty Logic and Mechanical operators. Mechanical operators are also known as Contactor or Electro-Mechanical operators. Efficiency in troubleshooting operators differs from this point. Logic operators have many LEDs and special controls to speed up diagnosis. For a Mechanical operator, refer to Section C. For Logic 3.0, 4.0, 5.0 operators, continue on to Section B.

Table of Contents

SECTION B

Logic Operators

Industrial Duty Logic Operators

	Page
Logic Board Overview	8
Troubleshooting	12
Selected Features	20
Diagnostic Chart	21
Symptoms And Solutions	22
Error Codes	24
Remote Controls	25

Medium Duty Logic Operators

	Page
Troubleshooting	27
Symptoms And Solutions	28
Error Codes	29
Programming	30

Logic Board Overview

B

Industrial Duty Logic Operators

LOGIC 5.0

Optional Auxiliary Card Receptacles

Motor Direction Jumper

Maximum Run Timer Button

Radio Learn Button

Mid Stop Learn Button

Timer-To-Close Learn Button

Selector Dial (used for programming and selecting wiring type)

Main Motor Control Harness Connection

Single Phase & Three Phase Jumper

Maintenance Alert System Button for Programming

Open Button

Close Button

Stop Button

Control Wiring Terminal Block

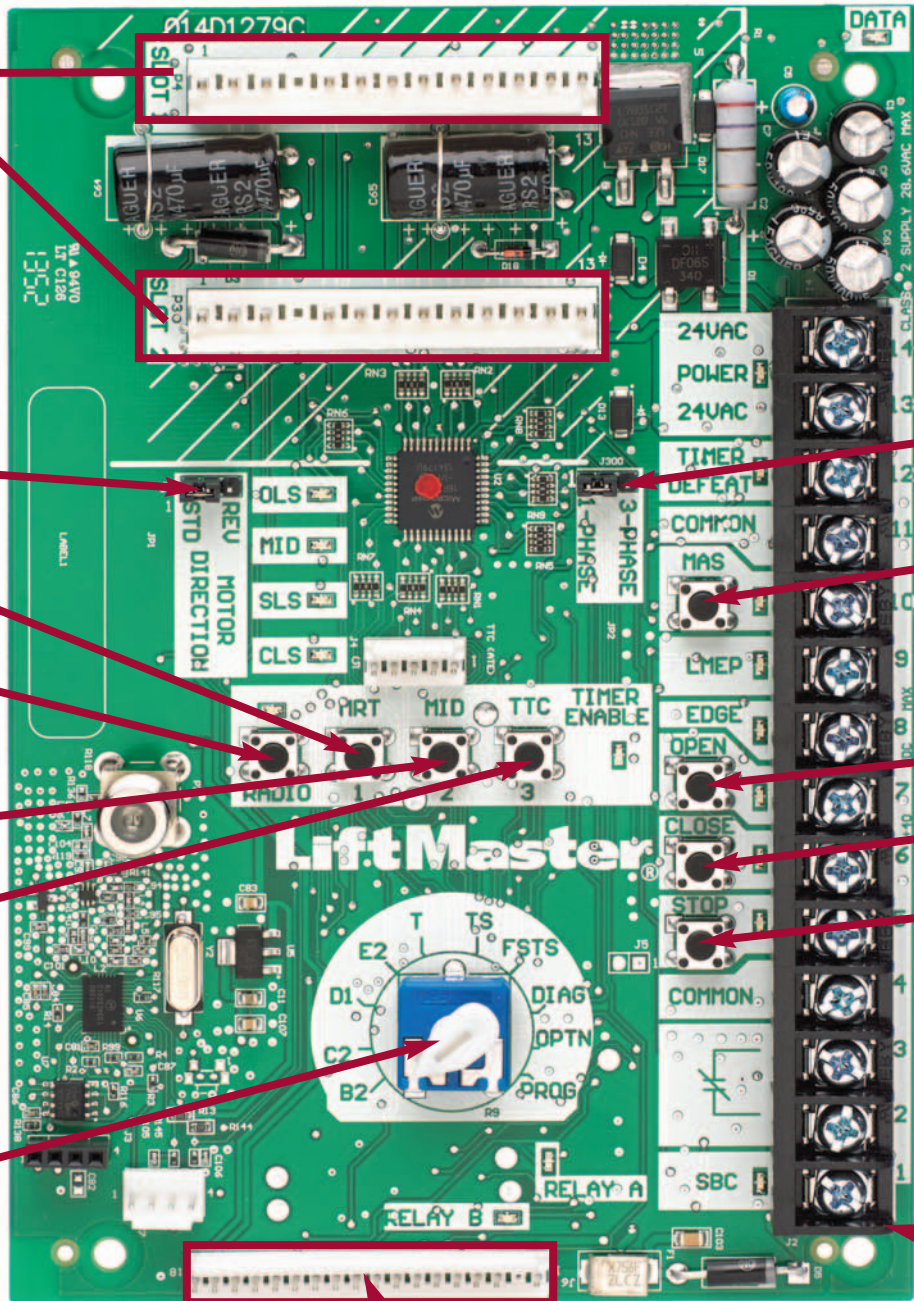

Logic Board Overview



Industrial Duty Logic Operators

Logic 5.0 Power Board - Dual Voltage Connections

- Reduces stocking a wide variety of operators due to range of potentially required voltages.
- Minimizes lost time if operator does not meet predetermined job site voltage requirements.

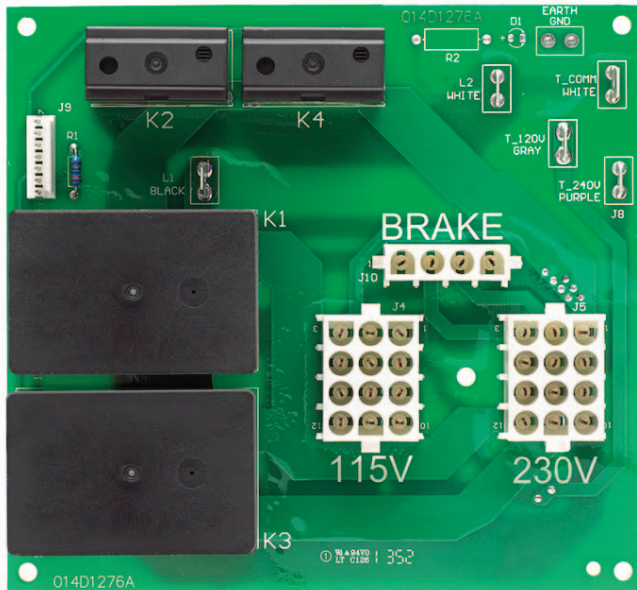

Single Phase Power Board
115V, 230V

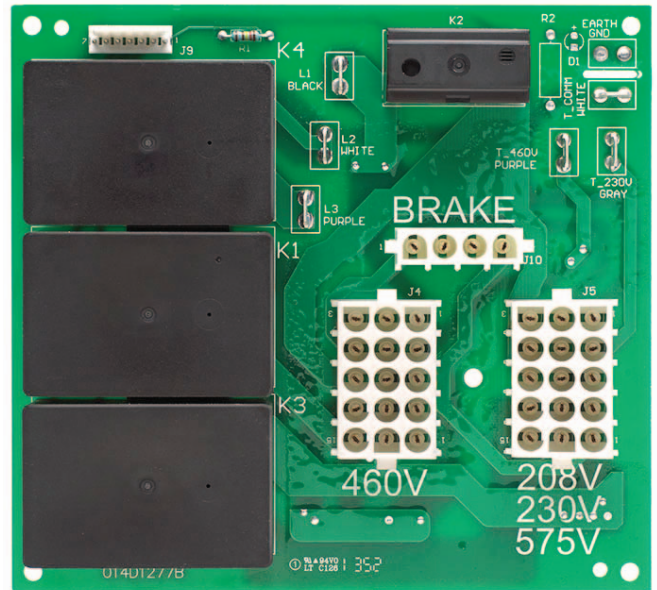

Three Phase Power Board
460V, 208V, 230V, 575V

Logic Board Overview

B

Industrial Duty Logic Operators

LOGIC 4.0

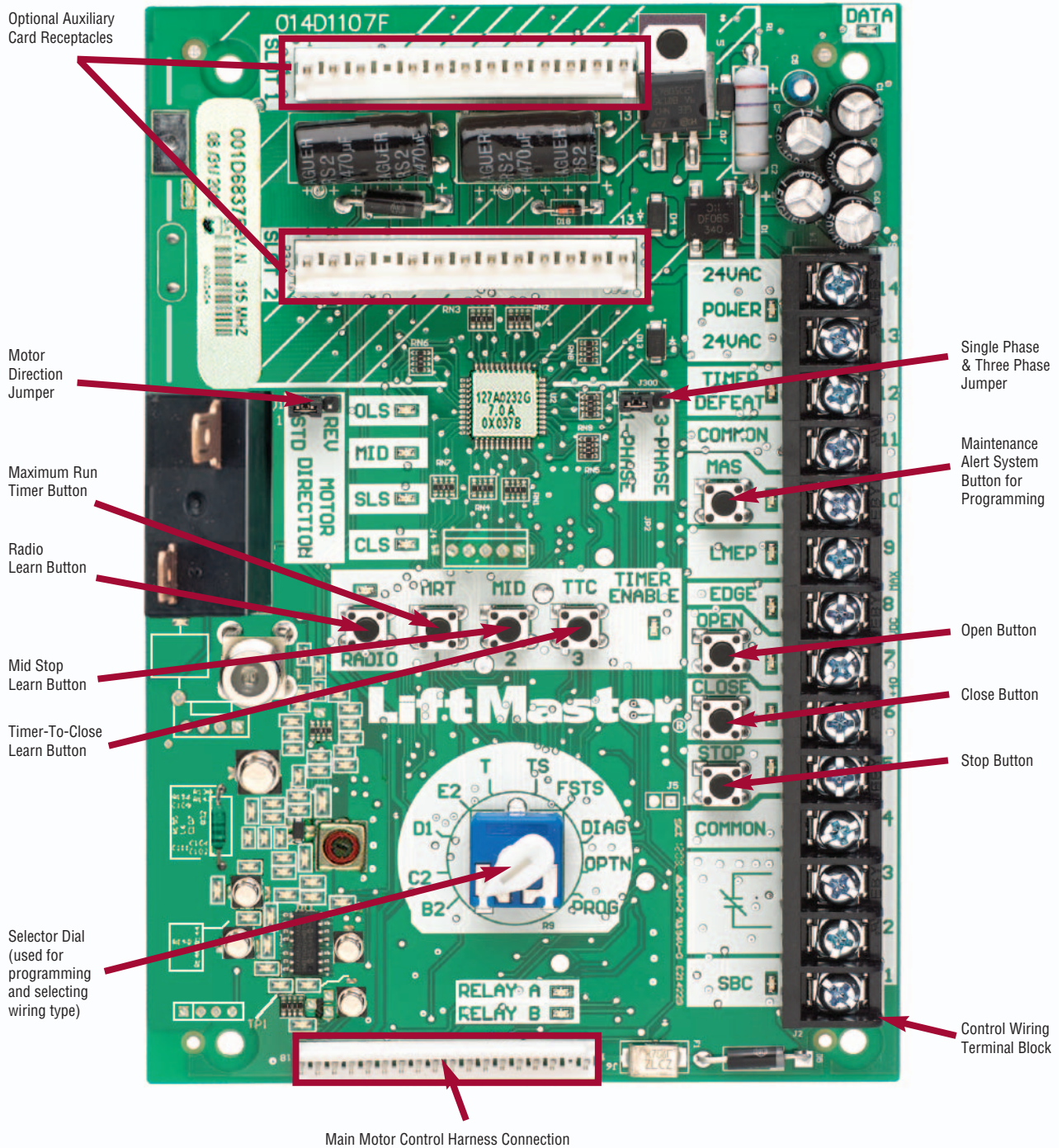

Logic Board Overview



Industrial Duty Logic Operators

LOGIC 3.0

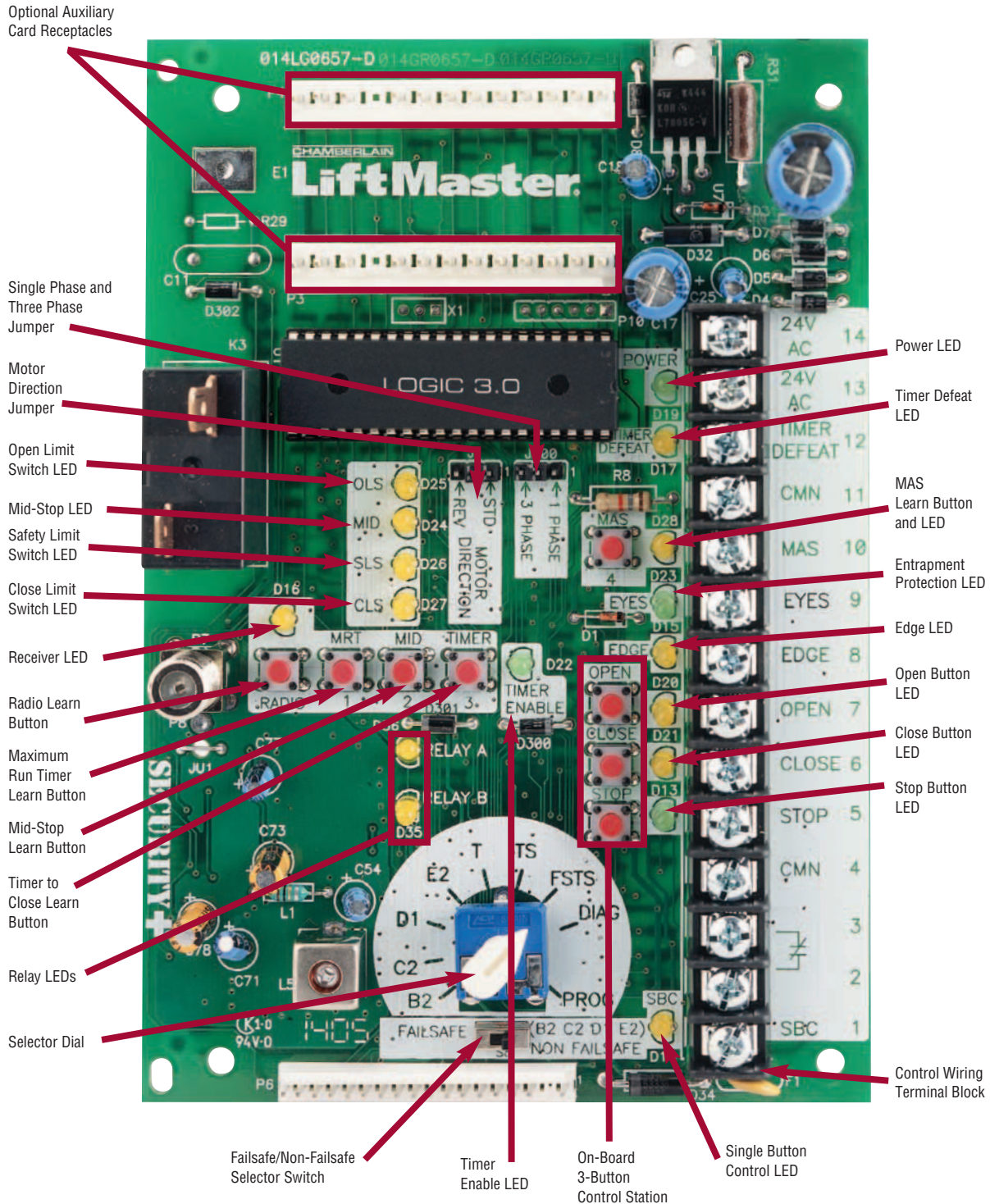

LiftMaster

Look For Green “POWER” LED

The Industrial Duty Logic Operator has many features reducing time required to identify and make repairs, as well as time spent training service technicians. Please note when working on an operator, always follow proper electrical safety guidelines and local codes.

The transformer should produce 24VAC ($\pm 10\%$) on the secondary side. This can easily be verified with a voltmeter or by looking at the green LED marked “POWER” near terminal #13. If the green LED is illuminated, 24VAC is present on the logic board. Verifying with a voltmeter is still recommended. To check the secondary side of the transformer, set the meter to volts AC and check across the yellow and blue wires on the transformer or terminals 13 and 14 on the logic board. If working properly, they should each show 24VAC $\pm 10\%$.

The logic board and all the controls are run on 5VDC. The 5VDC control signal allows 1000 ft. control runs with 18AWG wire. Be sure any incoming signal to the board is from a dry contact and not a voltage source. A dry contact, such as a standard switch, is a device connecting two wire leads to make a closed circuit. Some examples are the open or close buttons on LiftMaster’s standard 3-button control station, limit switches and standard relay outputs.

If the green “POWER” LED does not turn on, the transformer may not be working correctly. Verify primary voltage feeding the transformer by checking: Logic 3.0 and Logic 4.0 - White and Brown wires. Logic 5.0 - Common and appropriate wire. See the chart for high voltage wires.

Transformer - High Voltage Color Code

	LOGIC 3.0 AND LOGIC 4.0	LOGIC 5.0
115V	Brown and White	White and Gray
208/230V Single Phase	Brown and White	White and Purple
208/230V Three Phase	Brown and White	White and Gray
460V	Brown and White	White and Purple
575V	Brown and White	White and Gray

Check Control Station

Verify the control stations are wired to the terminal strip correctly. This is easily checked by using the “OPEN,” “CLOSE,” and “STOP” LED diagnostic LEDs. The operator should have the “OPEN” and “CLOSE” LEDs off and the green “STOP” LED on.

Turn the selector dial to DIAG to put the operator in diagnostic mode. Confirm the wiring is correct on the board by pressing the “OPEN” and “CLOSE” button on the board separately. When each button is pressed, the corresponding LED should turn on. When working properly, the STOP LED should be illuminated. Pressing the STOP button should make this LED turn off. If the LED’s respond accordingly to the on-board OPEN/CLOSE/STOP buttons, test the 3-button control station or the wiring to the 3-button control station.

To test the 3-button control station, open the control station and use a multimeter to verify continuity. When working properly, an idle 3-button control station with no depressed buttons should read infinite resistance (open circuit) across the “OPEN” and “CLOSE” buttons and 0 Ohms (closed circuit) across the “STOP” button. The meter should read 0 Ohms (closed circuit) when the “OPEN” and “CLOSE” buttons are pressed, and infinite resistance (open circuit) when the “STOP” button is pressed. If the continuity test on the 3-button control station yields different results than listed, the control station will have to be replaced.

Check Control Station (Continued)

Terminals 2 and 3 are also a normally closed circuit used when an external interlock is present. If the external interlock is activated the “STOP” LED will not be lit.

If the LEDs do not respond, disconnect the wall control station(s), put a jumper between the “STOP” and “COMMON” terminals, and try activating the LEDs by pressing the on-board 3-button control station next to the terminal strip. If the LEDs do not respond, there is a problem with the logic board and will require replacement.

If the lights do respond, but the operator still does not run, reset the operator to factory defaults.

Resetting Factory Defaults - Clearing Memory

To reset most of the user installed settings back to factory defaults:

- 1) Turn the selector dial to DIAGNOSTIC.
- 2) Press and hold the STOP button for 5 seconds. The MAS LED will flash momentarily when the factory defaults have been restored.
- 3) Return the selector dial to the desired wiring type.

Factory Defaults:

- a) Timer-To-Close is set to 0 seconds.
- b) The Mid Stop is deactivated.
- c) The Maintenance Alert System is deactivated.
- d) The Maximum Run Timer is set to 90 seconds.
- e) Car Dealer Mode is deactivated.
- f) The remote controls and MyQ® devices will still be learned.
- g) Remote control programming via the 3-button control station.
- h) The LiftMaster Monitored Entrapment Protection (LMEP) device(s) will be unprogrammed.

NOTE: Life of Operator feature (Odometer/Cycle Counter) and programmed remote controls and MyQ devices are not cleared.

SELECTOR DIAL

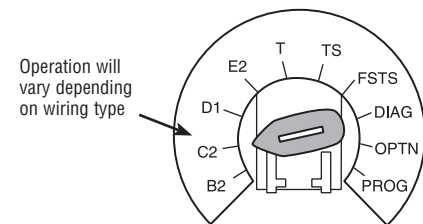
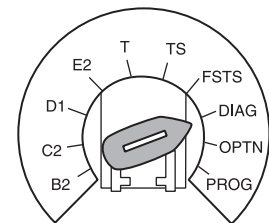

Advanced Troubleshooting: Testing Single Phase Logic 3.0 And 4.0 Relays

The following tests should be performed by a qualified technician. A voltmeter will be required.

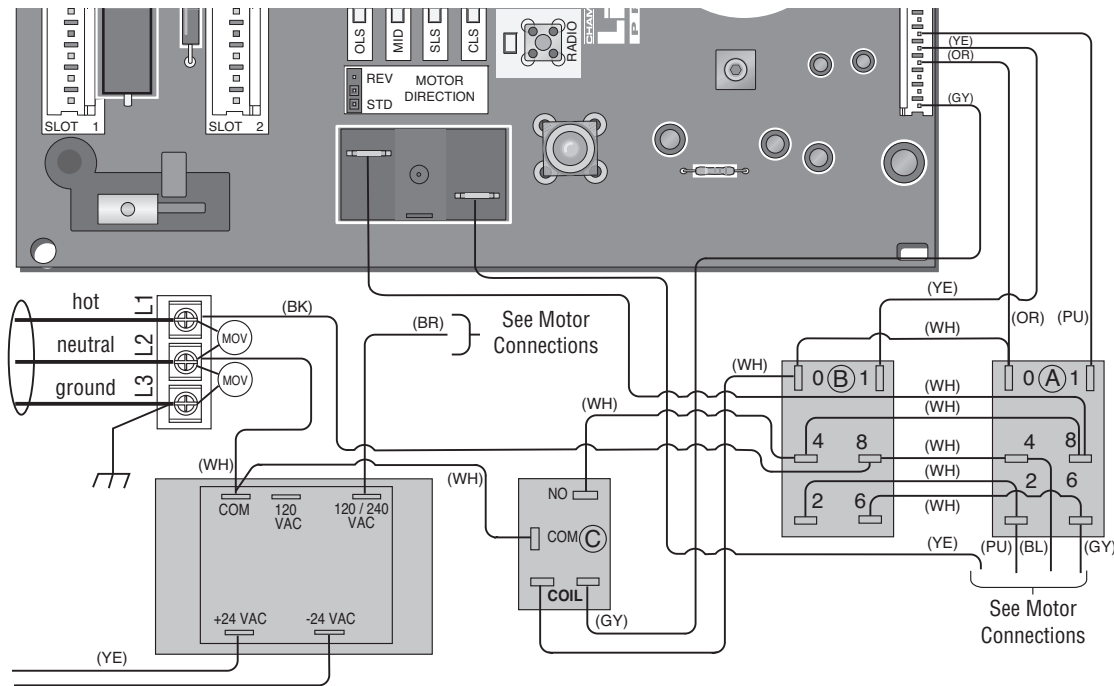

Testing C Relay

Check Coil Wires. 0VDC at idle, 24VDC when given a command either direction. Check NO Contact. Metering L1 to either white wire on C relay should read line voltage when given a command.

Testing B Relay

Check Coil Wires. 0VDC at idle, 24VDC when given an OPEN command. *Special applications might show voltage in the opposite direction.

Check NO Contact. Metering L2 to 6 on B relay should read line voltage when given an OPEN command. *Special applications might show voltage in the opposite direction.

Testing A Relay

Check Coil Wires. 0VDC at idle, 24VDC when given a CLOSE command. *Special applications might show voltage in the opposite direction.

Check NO Contact. Metering L2 to 2 on A relay should read line voltage when given a CLOSE command. *Special applications might show voltage in the opposite direction.

Testing K3 Relay (Start Winding Relay On Board With White And Yellow Wires)

K3 is a NO relay that closes for 1.25 seconds during start up. To test, remove White and Yellow wires and test for continuity across the contacts on the relay. Reading should be OPEN when operator is idle and should close for 1.25 seconds when operator is given a command.

NOTE: 1) This test will put the operator into a restricted close mode. Simply cycle power to reset.

2) If the K3 relay is stuck CLOSED, the motor will 'GRAWL' loudly and trip the circuit breaker.

3) If the K3 relay is stuck OPEN, motor will only hum.

Advanced Troubleshooting: Testing Three Phase Logic 3.0 And 4.0 Relays

The following tests should be performed by a qualified technician. A voltmeter will be required.

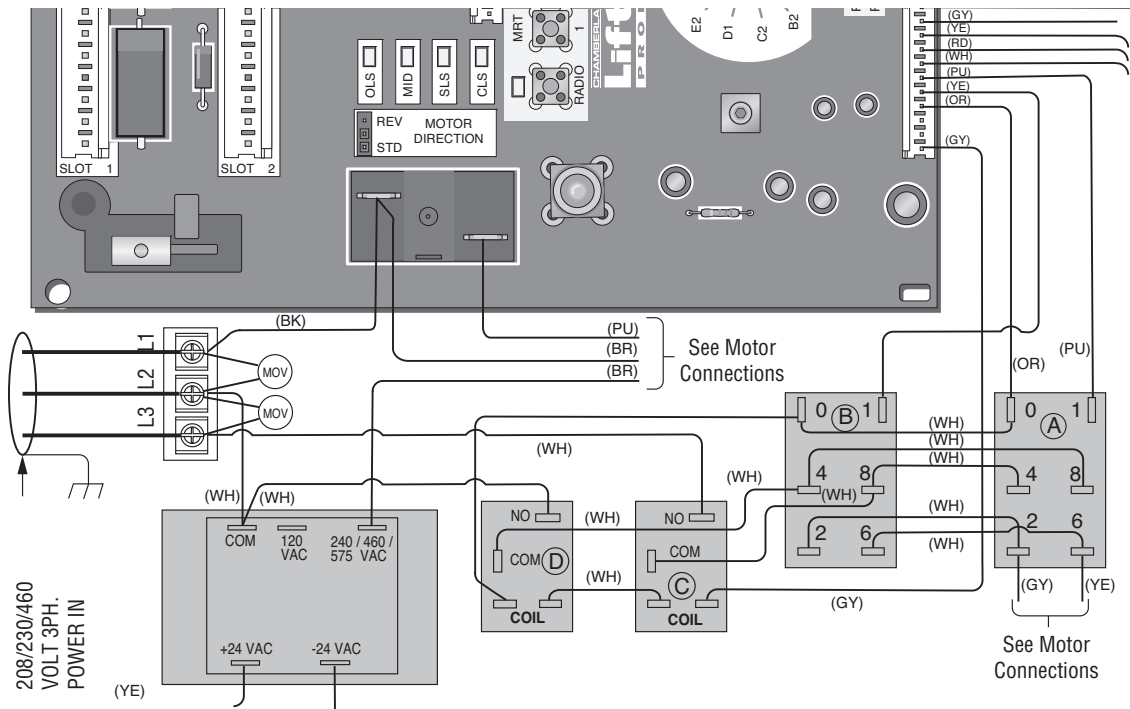

Testing C And D Relays

Check Coil Wires. Both are 0VDC at idle. Metering across either coil should read 12VDC when given a command.
 Check NO Contact. Metering L1 to either white wire on C or D relay should read line voltage when given a command.

Testing B Relay

Check Coil Wires. 0VDC at idle, 24VDC when given an OPEN command. *Special applications might show voltage in the opposite direction.

Check NO Contact. Metering L2 to 6 on B relay should read line voltage when given an OPEN command. *Special applications might show voltage in the opposite direction.

Testing A Relay

Check Coil Wires. 0VDC at idle, 24VDC when given a CLOSE command. *Special applications might show voltage in the opposite direction.

Check NO Contact. Metering L2 to 2 on A relay should read line voltage when given a CLOSE command. *Special applications might show voltage in the opposite direction.

Advanced Troubleshooting: Checking Logic 5.0 Single Phase Motor

The following tests should be performed by a qualified technician. A voltmeter will be required.

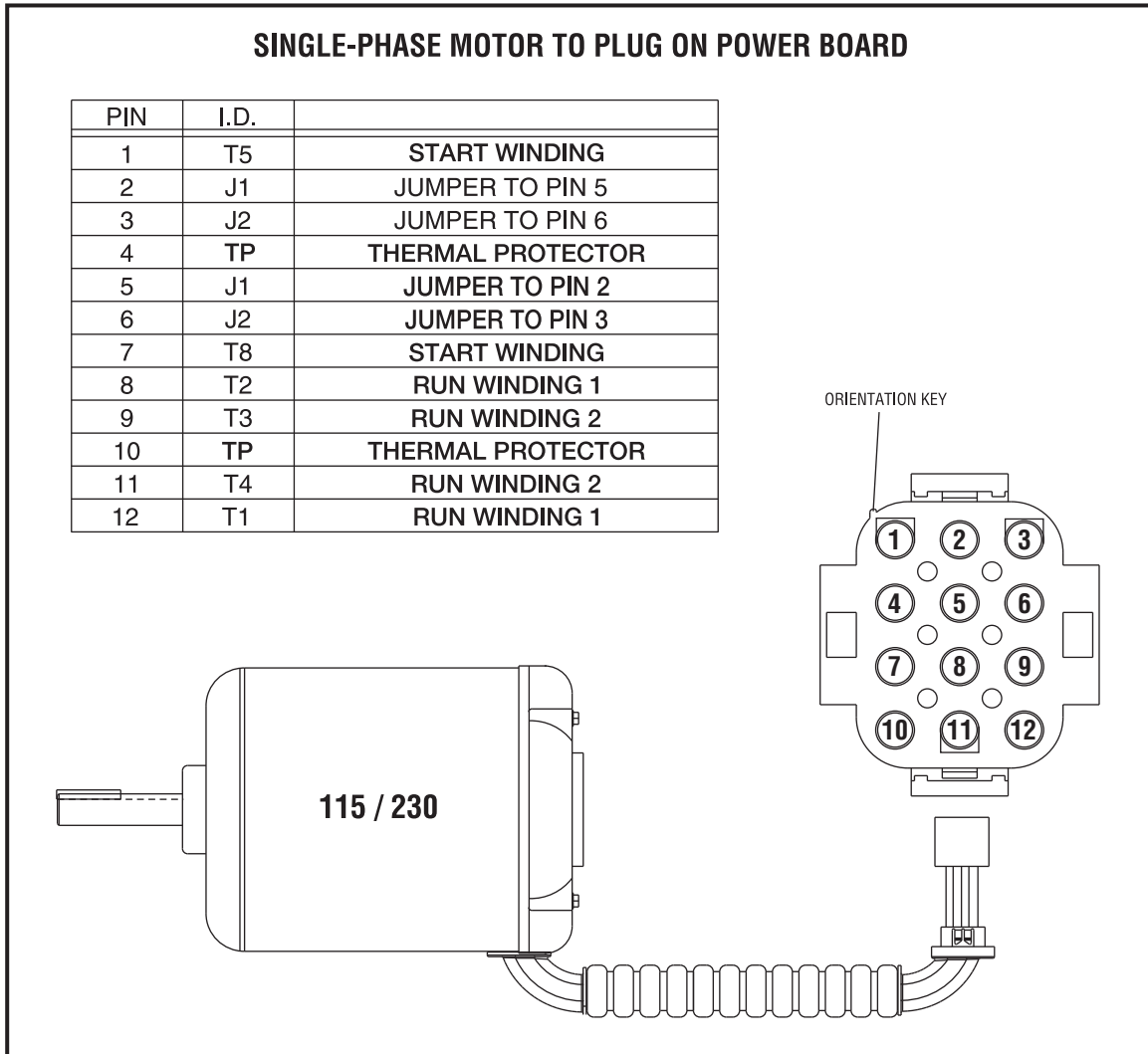

- 1) Turn power off to the operator.
- 2) Locate the motor plug on the POWER BOARD and unplug.
- 3) Set the voltmeter to continuity/ohms. Ω *Certain meters have a setting that beeps when a closed circuit is detected. This setting is preferred for the test.
- 4) Using the guide below, check for continuity across the following pins on the motor harness:
 - a. Place probe between Thermal Protector, Pins 4 and 10. Continuity should be present.
 - b. Place probe between Run Winding 1, Pins 12 and 8. Continuity should be present.
 - c. Place probe between Run Winding 2, Pins 11 and 9. Continuity should be present.
 - d. Place probe between Start Winding, Pins 1 and 7. Continuity should NOT be present.
- 5) If the readings are different than the results expected above, the motor will have to be replaced.

Advanced Troubleshooting: Checking Logic 5.0 Three Phase Motor

The following tests should be performed by a qualified technician. A voltmeter will be required.

THREE-PHASE MOTOR TO PLUG ON POWER BOARD

208/230-460 VAC THREE PHASE

PIN	I.D.	
1	TP	THERMAL PROTECTOR
2	J1	JUMPER TO PIN 3
3	J2	JUMPER TO PIN 2
4	TP	THERMAL PROTECTOR
5	T6	MOTOR WINDING 3
6	T9	MOTOR WINDING 4
7	T5	MOTOR WINDING 2
8	T4	MOTOR WINDING 1
9	T3	MOTOR WINDING 3
10	J3	JUMPER TO PIN 13
11	T7	MOTOR WINDING 4
12	T8	MOTOR WINDING 4
13	J4	JUMPER TO PIN 10
14	T1	MOTOR WINDING 1
15	T2	MOTOR WINDING 2

575 VAC THREE PHASE

PIN	I.D.	
1	TP	THERMAL PROTECTOR
2	J1	JUMPER TO PIN 3
3	J2	JUMPER TO PIN 2
4	TP	THERMAL PROTECTOR
5	NC	
6	NC	
7	NC	
8	NC	
9	T3	MOTOR WINDING
10	J3	JUMPER TO PIN 13
11	NC	
12	NC	
13	J4	JUMPER TO PIN 10
14	T1	MOTOR WINDING
15	T2	MOTOR WINDING

ORIENTATION KEY

- 1) Turn power off to the operator.
- 2) Locate the motor plug on the POWER BOARD and unplug.
- 3) Set the voltmeter to continuity/ohms. Ω *Certain meters have a setting that beeps when a closed circuit is detected. This setting is preferred for the test.
- 4) Using the guide below, check for continuity across the following pins on the motor harness:
 - a. Place probe between Thermal Protector, Pins 1 and 4. Continuity should be present.
 - b. Place probe between Motor Winding 1, Pins 14 and 8. Continuity should be present.
 - c. Place probe between Motor Winding 2, Pins 15 and 7. Continuity should be present.
 - d. Place probe between Motor Winding 3, Pins 9 and 5. Continuity should be present.
 - e. Place probe between Motor Winding 4, Pins 6, 11 and 12. Continuity should be present. *Any combination between Pins 6, 11 and 12, continuity should be present.
- 5) If the readings are different than the results expected above, the motor will have to be replaced.

Advanced Troubleshooting: Checking Logic 5.0 Single Phase Brake And Power Board

The following tests should be performed by a qualified technician. A voltmeter will be required.

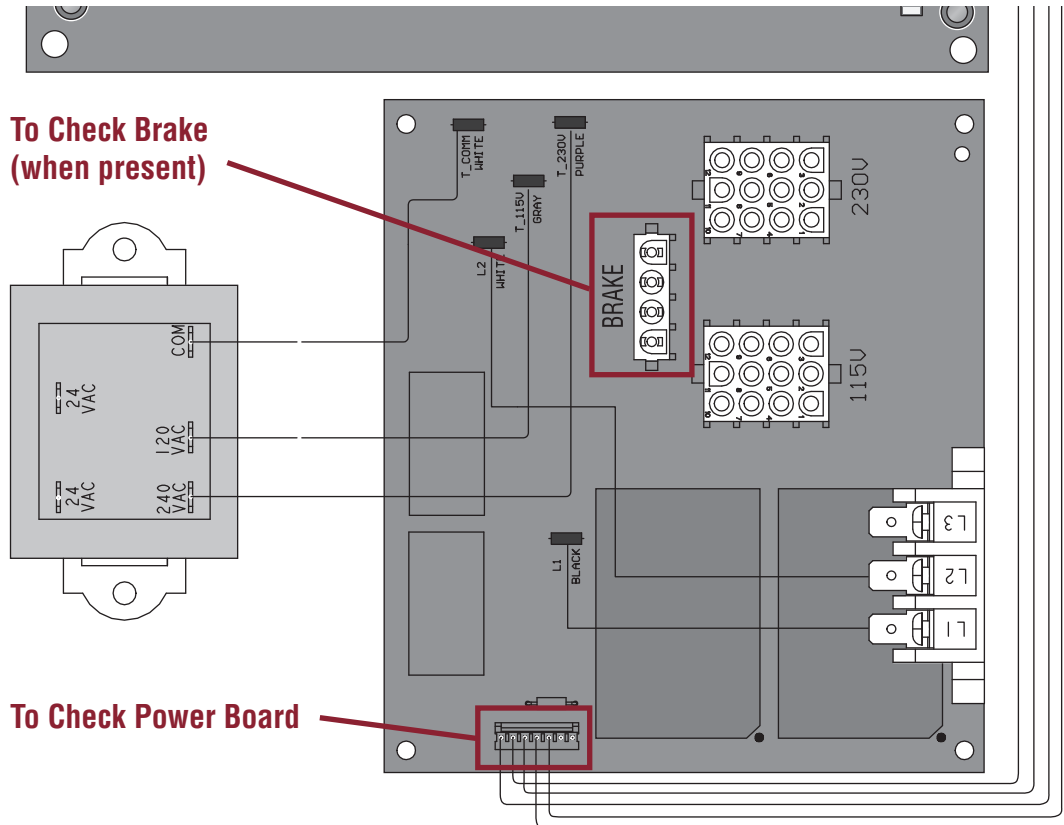

To Check Brake (When Present)

- 1) Turn power off to the operator.
- 2) Locate the brake plug on the POWER BOARD and unplug.
- 3) Set the voltmeter to continuity/ohms. Ω *Certain meters have a setting that beeps when a closed circuit is detected. This setting is preferred for the test.
- 4) Using the guide below, check for continuity across the following pins on the brake harness:
 - a. On 115v operators, place probe between the White and Yellow wires on the brake harness. Continuity should be present.
 - b. On 208/230v operators, place probe between the Blue and Black on the brake harness. Continuity should be present.
- 5) If the readings are different than the results expected above, the brake solenoid will have to be replaced.

To Check Power Board

This measurement is done with power removed from the operator and the low voltage harness plugged in to the Power Board. Set meter to ohms(Ω) and check :

- Orange to Gray should read 335 ohms
- Orange to Purple should read 648 ohms
- Orange to Black should read 335 ohms
- Orange to Yellow should read 648 ohms

*Readings are to allow +/- 10% deviation If the readings are different than the results expected above, the Power Board will have to be replaced.

Advanced Troubleshooting: Checking Logic 5.0 Three Phase Brake And Power Board

The following tests should be performed by a qualified technician. A voltmeter will be required.

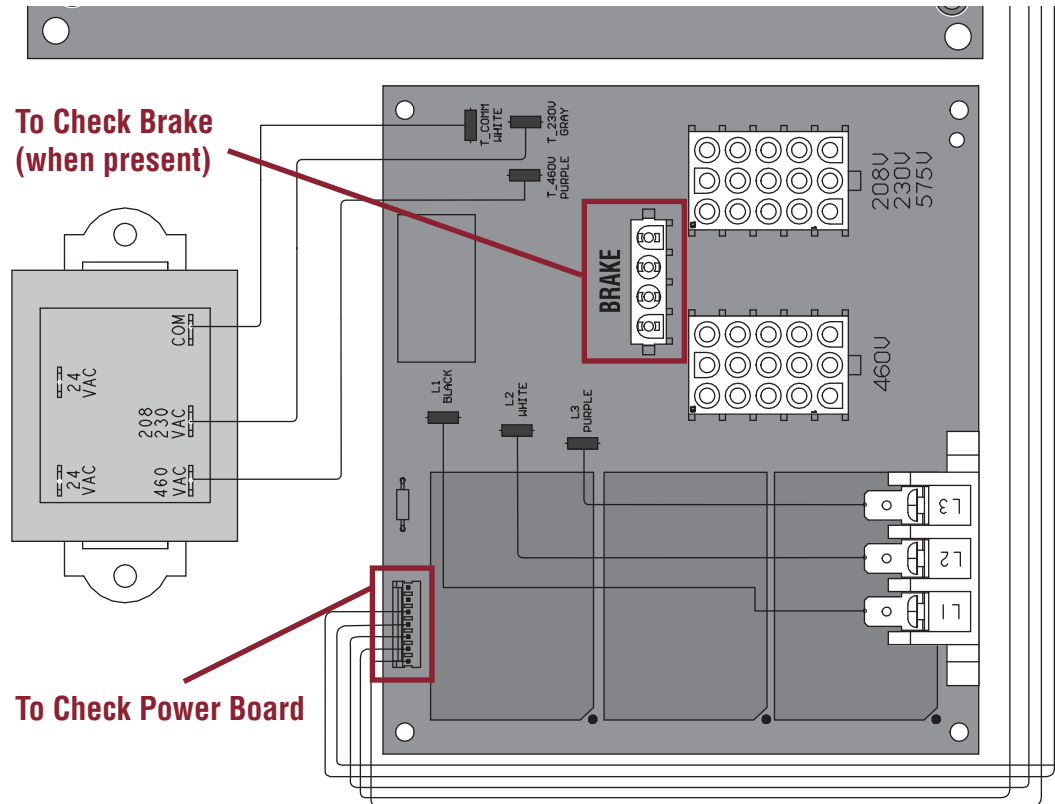

To Check Brake (When Present)

- 1) Turn power off to the operator.
- 2) Locate the brake plug on the POWER BOARD and unplug.
- 3) Set the voltmeter to continuity/ohms. Ω *Certain meters have a setting that beeps when a closed circuit is detected. This setting is preferred for the test.
- 4) Using the guide below, check for continuity across the following pins on the brake harness:
 - a. Place probe between Pins 1 and 4 on the brake harness. Continuity should be present.
- 5) If the readings are different than the results expected above, the brake solenoid will have to be replaced.

To Check Power Board

This measurement is done with power removed from the operator and the low voltage harness plugged in to the Power Board. Set meter to ohms(Ω) and check :

- Orange to Gray should read 350 ohms
- Orange to Purple should read 640 ohms
- Orange to Black should read 350 ohms
- Orange to Yellow should read 350 ohms

*Readings are to allow +/- 10% deviation If the readings are different than the results expected above, the Power Board will have to be replaced.

Car Dealer Mode

Feature: The car dealer mode uses the SBC (Single Button Control input) to bring the door from a closed position to the programmed Open Mid-Stop position and keep it at that location even with multiple inputs.

Benefit: Provides energy cost savings by limiting the door opening height.

Requirements: This feature works in conjunction with the programmable Timer-To-Close feature. To enable this feature you must first connect a treadle, photoelectric sensor or loop detector accessory to the SBC input and must have at least one LiftMaster Monitored Entrapment Protection (LMEP) device installed (refer to the installation manual). Wiring type must be set to TS or T.

TO PROGRAM:

- 1) Start with the door in the closed position.
- 2) Turn the SELECTOR DIAL to PROG.
- 3) Push the TTC button and release (Green Timer LED will be lit).
- 4) Push the MID button and release. This turns on the Car Dealer Mode. (The Green Timer LED will flash 6 times indicating the Car Dealer Mode is turned on.)
- 5) Push the TTC button and release.
- 6) Turn the SELECTOR DIAL to the desired wiring type (TS or T).

NOTE: To disable the Dealer Mode follow steps 2 and 3, then press the MRT button and release. (The Green Timer LED will flash 3 times indicating that the Car Dealer Mode is off.)

Life Of Operator (Odometer/Cycle Counter)

The operator is equipped with an odometer to show how many months and cycles the operator has performed from the time it was installed. This feature can help determine how long the operator has been in service.

- 1) Start with the door in the closed position.
- 2) Turn the SELECTOR DIAL to DIAG (diagnostic mode).
- 3) Press and release the MAS button on the logic board.
- 4) Press and release the MRT button on the logic board.
- 5) The open and close lights will flash. OPEN for every 5,000 cycles and CLOSE for every 3 months.
- 6) Return the SELECTOR DIAL to the desired wiring type.

NOTE: If operator has not reached 5,000 cycles or 3 months, there will be no indications.

Thermal Overload

The Logic operators have been equipped with a thermal motor overload. The thermal overload has replaced the need for a manual overload on the operator electrical box. The thermal overload works by shutting down the operator until the operator can cool off and reset automatically. After the overload resets, the operator must be cycled with constant pressure. The operator must be opened and closed fully to reset the operator to normal operation. This feature saves the installer from having to physically reset the operator manually.

Motor Direction Jumper

This feature is designed to save the installer from having to rewire the limit switches and motor when unique applications require reversing the open and close limits. This would typically be seen on an auxiliary trolley modification, through-wall application, or when mounting the operator upside down. By removing the jumper from the motor direction pins, the door can be set to either a standard or reversed direction. The factory default is the standard direction. The logic board automatically changes the motor direction and reverses the Open Limit Switch (OLS) and the Close Limit Switch (CLS). The only limit switch requiring movement is the Sensing Limit Switch (SLS) to the close side of the operator. This feature is provided for ease of install.

SELECTOR DIAL

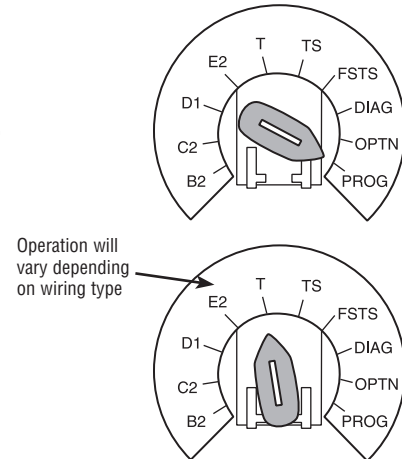

Diagnostic Chart



Industrial Duty Logic Operators

The industrial duty logic boards (5.0, 4.0, 3.0) have several LEDs to assist in the installation and troubleshooting of the operator. The following chart should assist in verifying the operator is functioning properly. Turn the selector dial to DIAGNOSTIC to keep the door from moving while troubleshooting.

LED	COLOR	DEFINITION
Power	Green	Indicates power is being generated for the logic board.
Stop	Green	Indicates a closed circuit between Common terminal 4 and Stop terminal 5. Pressing stop should turn off this LED.
Open	Yellow	Indicates a closed circuit between Common terminal 4 and Open terminal 7. Pressing the open button should turn ON this LED.
Close	Yellow	Indicates a closed circuit between Common terminal 4 and Close terminal 6. Pressing the close button should turn ON this LED.
LMEP (Photoelectric sensors) (CPS-U, CPS-UN4)	Green	Solid on indicates LMEP learned. Flashing indicates sensors need to be re-connected or activated, or unlearned if removed**. Solid off indicates no sensors learned.
Timer Defeat	Yellow	Solid on indicates a closed circuit between common and terminal 12. Timer-To-Close will not close.
OLS	Yellow	Pressing the Open Limit Switch should turn ON this LED.
CLS	Yellow	Pressing the Close Limit Switch should turn ON this LED.
SLS	Yellow	Pressing the Sensing Limit Switch should turn ON this LED.
Edge	Yellow	Indicates a closed circuit between common and terminal 8. Pressing the edge should turn ON this LED.
Mid-Stop	Yellow	Solid on indicates door is stopped on mid-stop.
Timer Enabled	Green	Solid on indicates TIMER is programmed and will activate from open or mid stop position. Flashing indicates TIMER is counting down and door will close after preset time. Each flash represents 1 second of programmed time.
SBC	Yellow	Indicates a closed circuit between common and terminal 1. Pressing the single button control station should turn ON this LED.
MAS	Yellow	Indicates the Maintenance Alert System has been activated or an error code has been triggered. See inside cover of the operator.
Relay A	Yellow	Indicates open or close command has been given to the motor. LED turns on when OPEN/CLOSE button is pressed.
Relay B	Yellow	Indicates open or close command has been given to the motor. LED turns on when OPEN/CLOSE button is pressed.
DATA*	Green	Indicates communication between the Logic 5.0 board and optional TLS1CARD.

* Logic 5.0 ONLY

** To unlearn, turn the selector dial to DIAG. Press and hold the STOP button until the MAS LED flashes (5 flashes). Return the selector dial to the desired wiring type.

SYMPTOM: The Operator Will Not Respond To Any Commands	
POSSIBLE CAUSE:	SOLUTION:
No power supply	Verify primary line voltage from power source. Green POWER LED must be on.
Operator 3-button control station is miswired	Use the OPEN, CLOSE and STOP LEDs to help check correct wiring. Verify the logic board is accepting commands by using the on-board 3-button control station. Green light next to the STOP button must be on.
Interlock switch is activated	Check interlock(s). If more than one external interlock is present they must be wired in series.
Dial still in programming or diagnostic mode	Set dial to desired wiring type.
Motor is malfunctioning	Verify proper voltage getting to the motor.
Motor thermal overload tripped	Check for obstructions and verify the door moves freely. Cycle operator in constant pressure one full cycle open and close to reset fault. Check to see if motor is hot. Allow motor to cool before attempting to move door.
Failsafe switch is activated requiring photoelectric sensors (Logic 3.0 only)	Move switch to non-failsafe or connect a failsafe sensing device.
LiftMaster Monitored Entrapment Protection (LMEP) not installed (Logic 4.0 and 5.0)	Move selector dial to C2 for constant pressure to close or add a LiftMaster Monitored Entrapment Protection (LMEP).
A relay or the power board (Logic 5.0 ONLY) may need to be replaced	When the OPEN or CLOSE button is pressed, Relay A or B LED should turn on and the door should move in the corresponding direction. If Relay A or B lights and the door does not move, the relay or Power Board (Logic 5.0 ONLY) may need to be replaced.
Possible accessory malfunction	Disconnect all devices; reattach them one at a time testing for a failure after each one is replaced.
Possible logic board failure	Replace logic board.
SYMPTOM: Power LED Is Not On	
POSSIBLE CAUSE:	SOLUTION:
Loose secondary wiring connections or a faulty control transformer	Repair or replace connections or control transformer.
Logic board failure	Replace logic board.
Interlock switch	Check interlock(s).
SYMPTOM: Stop Button LED Is Not On	
POSSIBLE CAUSE:	SOLUTION:
Control station miswired or not connected	Check wiring to control station.
Interlock switch	Check interlock switch(es) for continuity.

SYMPTOM: The Door Will Move About A Foot, Then Stop. After Stopping, Only Constant Pressure Commands Will Move The Door	
POSSIBLE CAUSE: RPM sensor is not connected properly or may need to be replaced	SOLUTION: a) Check the RPM assembly for loose connections. Check the Interrupter Cup to ensure it turning when the operator is running. Check for foreign matter blocking the optical lens. b) Replace RPM sensor.
SYMPTOM: The Door Will Move Most Of The Way Towards A Limit, Then Stop. An Extra Open Or Close Command Is Able To Get Door To Complete Cycle	
POSSIBLE CAUSE: The Maximum Run Timer is not set correctly	SOLUTION: Manually reprogram the Maximum Run Timer OR reset to factory defaults.
SYMPTOM: The Door Will Open Partway And Stop. A Second Open Command Is Needed To Open The Door Completely.	
POSSIBLE CAUSE: There may be a Mid-Stop set	SOLUTION: Check to see if the Mid-Stop LED is on. Clear the Mid-Stop by turning the selector dial to program. Press and hold the Mid-Stop button for 5 seconds. Return dial to desired wiring type.
SYMPTOM: The Door Will Open But Will Only Close After A Five Second Delay With Constant Pressure On The Close Button	
POSSIBLE CAUSE: The photoelectric sensor, sensing edge or other entrapment protection device is obstructed or activated	SOLUTION: If the on-board EYES LED is flashing, the photo-eyes are misaligned or not connected. Remove any obstructions; check the safety device wires for continuity or a short.
The logic board thinks the photoelectric sensors are attached and blocked	Erase the LMEP device; turn the selector dial to DIAG, push and hold the stop button until the MAS LED flashes. If a LiftMaster entrapment protection device is not connected the only modes of operation are C2, D1 or E2.
Failsafe switch set (L3 only)	Slide switch to Non-Failsafe mode.
SYMPTOM: The Operator Will Not Respond To Any Commands	
POSSIBLE CAUSE: Possible accessory malfunction	SOLUTION: Disconnect all devices; reattach one at a time testing for a failure after each one is replaced.
Possible logic board failure	Replace logic board.

LiftMaster Logic 3.0, 4.0, and 5.0 Operators incorporate a self-diagnostic feature built into the MAS LED. In addition to indicating when routine maintenance is due, the MAS LED can be used to troubleshoot problems with the operator.

If the MAS LED on the logic board or 3-button control station is flashing on and off rapidly, the Maintenance Alert System has been triggered and service is due on the operator. If the MAS LED flashes 2 or more times in a row followed by a pause, an operator error has occurred. To view the errors, turn the selector dial to DIAGNOSTIC and press the OPEN button. To view the individual error codes (if more than one exists) press CLOSE. It is possible to have more than one error at a time. Use the chart below to determine the error.

ERROR CODE	DESCRIPTION	SYMPTOM	SOLUTION
1 blink	MAS triggered (cycles or months)	Normal operation	Reset MAS.
2 blinks	No RPM input during opening or closing	The door only responds to constant pressure commands	Clutch is slipping; adjust clutch, or verify RPM sensor connection or replace RPM sensor. NOTE: To relearn the RPM sensor, move the door with a constant pressure command. The door will stop once relearned and normal operation will resume.
3 blinks	(MRT) Maximum Run Time has timed out	The door stops before reaching the desired time	Check the operator for any faults (e.g., bad limit switch), program the Max Run Timer OR reset to factory defaults.
4 blinks	Obstruction sensed on closing	Operator will reverse to OPEN position	Remove obstructions or realign photoelectric sensor.
5 blinks	A button is stuck (longer than 2 minutes)	The control station will not respond	The control station must be fixed or replaced before it will be recognized as an input.
6 blinks	Invalid option card plugged into option card receptacles	Option card will not function properly	Refer to accessories (page 63) for list of supported option card(s).
7 blinks	LiftMaster Monitored Entrapment Protection (LMEP) device faulted or removed for greater than 2 minutes	Normal operation (5 second constant pressure override required to close)	Cleared when entrapment protection device is cleared or connected.
8 blinks	Brownout detected	Operator will run as long as enough power is present	1. Check AC line for voltage. 2. Check transformer secondary for low voltage. Too many accessories may be connected to the transformer.
9 blinks	Motor movement at invalid time	Operator will continue to function normally for 5 operations and then default to a constant pressure mode	Check relays and the drive circuitry to insure that they are turning off. Operator must run correctly for two starts for the error to be cleared.
10 blinks	Operator was not in programming mode when the motor phase jumper was changed.	The phase will not change	Enter programming mode and move phase jumper to change phase.

NOTES: Error codes take priority over normal MAS LED operation. Error codes will repeat on the MAS every 1.5 seconds until cleared. There may be more than one error present, but only the highest priority will flash. If the highest error is cleared, the next highest will flash. All errors self-correct when corrective action is taken and a reset is not needed.

Error Codes

Error codes will be displayed by the radio receiver LED on the logic board.

NOTE: The Logic 3.0 and Logic 4.0 radio receivers are compatible with Security+® 315MHz remote controls and DIP switch remote controls. The Logic 5.0 radio receiver is compatible with Security+ 2.0™ remotes and keyless entry devices.

ERROR CODE	SYMPTOM	DISPLAY	POSSIBLE CAUSE	SOLUTION
R1	No response from the remote	Quick Flash	Unlearned remote – A user tries to use a remote, but the RADIO LED only flashes briefly and there is no response from the operator.	Try relearning the remote.
R2	No response from the remote	No LED activity	Cannot recognize remote – A weak signal caused by a discharged battery or outside interference with the radio OR is not compatible with the operator.	Replace battery OR eliminate interference OR obtain a compatible remote.
R3	The remote cannot be programmed	Radio LED turns off after 30 seconds	Cannot recognize remote – A weak signal caused by a discharged battery or outside interference with the radio OR is not compatible with the operator.	Replace battery OR eliminate interference OR obtain a compatible remote.
R4	The remote cannot be programmed	2 blinks	Receiver memory full – A user enters RADIO programming mode but there is no space available to add another remote.	Erase all learned remotes and relearn the desired remote(s).
R5	The remote cannot be programmed	3 blinks	Duplicate remote – A user enters RADIO programming mode and selects the function to be programmed. When the remote button is pressed for programming, a search reveals that remote is already programmed.	This remote already has a function associated with it. To change the function, erase all programmed remotes and reprogram the desired remote(s).
R6	Cannot close via constant pressure in C2, D1 or E2 modes	LMEP LED flashes	No entrapment protection device present – An entrapment protection device is required to close via remote.	Must connect a LiftMaster Monitored Entrapment Protection (LMEP) device.

Compatibility Chart - 315 & 390MHz And Security+ 2.0™

		Compatible with these CDO Models that have On-Board Radio Receivers				
MODEL	DESCRIPTION	LOGIC 5.0	LOGIC 4.0 315MHZ	LOGIC 4.0 390MHZ	ATS (PURPLE LEARN BUTTON)	MEDIUM-DUTY LOGIC
Remote Controls						
893MAX	3-Button Remote Control w/ Security+ 2.0 and MAX Technology	X	X	X	X	X
895MAX	3-Button Premium Remote Control w/ Security+ 2.0 and MAX Technology	X	X	X	X	X
811LM	1-Button Remote Control w/ DIP and Security+ 2.0 Technology	X				
813LM	3-Button Remote Control w/ DIP and Security+ 2.0 Technology	X				
891LM	1-Button Remote Control w/ Security+ 2.0 Technology	X				
893LM	3-Button Remote Control w/ Security+ 2.0 Technology	X				
371LM	1-Button Remote Control 315MHz w/ Security+ Technology		X		X	X
372LM	2-Button Remote Control 315MHz w/ Security+ Technology		X		X	X
373LM	3-Button Remote Control 315MHz w/ Security+ Technology		X		X	X
374LM	4-Button Remote Control 315MHz w/ Security+ Technology		X		X	X
333LM	3-Button Remote Control 315MHz Red/Yellow/Green w/ Security+ Technology		X		X	X
971LM	1-Button Remote Control 390MHz w/ Security+ Technology			X		
973LM	No longer available. Use 893MAX as its replacement			X		
Wireless Keypads						
877MAX	Wireless Keypad with Security+ 2.0 and MAX Technology	X	X	X	X	X
877LM	Wireless Keypad with Security+ 2.0 Technology	X				
377LM	Wireless Keypad 315MHz w/ Security+ Technology		X		X	X
387LM	Wireless Keypad - Universal	X	X	X	X	X

MEDIUM DUTY LOGIC BOARD

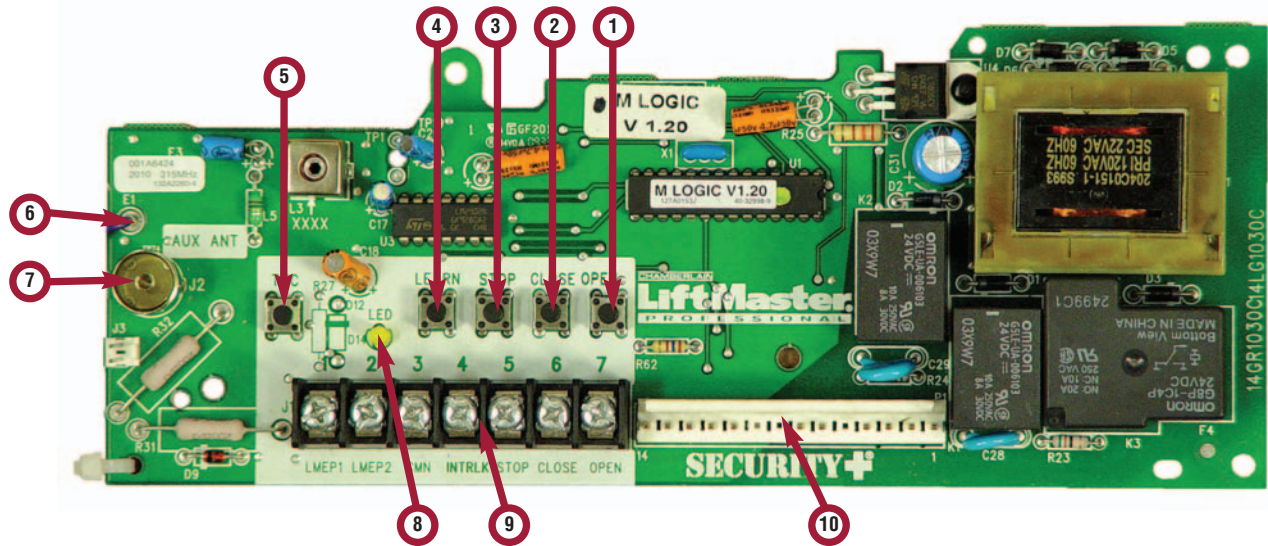

ITEM	DESCRIPTION	FUNCTION
1	Open Button	Open Door
2	Close Button	Close Door
3	Stop Button	Stop Door
4	Learn Button	Programs the remote controls and performs additional programming.
5	Timer-to-Close Button	Programs the Timer-to-Close.
6	Purple Wire Antenna	Primary Antenna.
7	Auxiliary Antenna Connection	For use with external antenna kit -EXT-ANT. Not provided.
8	LED	Used during programming and diagnosing error codes.
9	Field Wiring Terminal	Field wiring connections.
10	Factory Wiring Connector	Factory wiring harness connection.

Symptoms and Solutions



Medium Duty Logic Operators

SYMPTOM: Operator Will Not Respond To Any Commands	
POSSIBLE CAUSE:	SOLUTION:
No power	Verify primary line voltage (120 Vac, 60 Hz) is present at terminals L1 & L2. The LED will flash when power is present.
Stop circuit not complete	Verify Stop Button input (terminals 3 & 5) is properly wired and stop button is not stuck.
Stuck button on 3-button control station	Verify that all buttons are actuating freely and releasing properly.
Interlock input activated	a) Verify jumper is located at terminals 3 & 4 if interlock is not present. b) Verify interlock is properly wired and not activated when present.
Motor overload tripped	Overload is internal within motor. Allow to cool and retry.
Accessory failure	a) Attempt to close by holding the CLOSE button for more than 5 seconds. If door closes, check LiftMaster Monitored Entrapment Protection (LMEP) for proper wiring, polarity, connections or damage. b) Remove obstructions or realign photoelectric sensor.
Possible component failure	Call Technical Support for assistance.
SYMPTOM: Operator Makes Noise But Door Does Not Move	
POSSIBLE CAUSE:	SOLUTION:
Clutch slipping	Adjust clutch, see owner's manual.
Brake not releasing (if present)	Verify brake assembly operation and wiring.
Door operation problem	Check door for proper operation.
SYMPTOM: Operator Moves In The Wrong Direction	
POSSIBLE CAUSE:	SOLUTION:
OPEN and CLOSE button wiring connection reversed	Check 3-button control wiring.
SYMPTOM: Door Drifts After Operator Stops	
POSSIBLE CAUSE:	SOLUTION:
Door not balanced properly	Check door for proper operation.
Clutch slipping	Adjust clutch, see owner's manual.
Brake not functioning properly (if present)	Check brake mechanism to ensure brake lever is free and brake pads are engaging the brake disc.
SYMPTOM: Door Opens/Closes Too Far	
POSSIBLE CAUSE:	SOLUTION:
Limits not adjusted properly	Adjust limits. See owner's manual.
SYMPTOM: Door Reverses Unexpectedly	
POSSIBLE CAUSE:	SOLUTION:
Intermittent Entrapment Protection Device activation	Check all connections. Remove obstructions or realign photoelectric sensor.
SYMPTOM: TTC Not Functioning	
POSSIBLE CAUSE:	SOLUTION:
LiftMaster Monitored Entrapment Protection Devices	Check all connections. Verify photoelectric sensors are not blocked and the sensing edge (if installed) is not activated.
TTC temporarily disabled	Close and Open the door. TTC will be re-enabled.
TTC not programmed properly	Reprogram TTC. See see owner's manual.
Radio Functionality <i>NOTE: Built in radio receiver compatible with all LiftMaster 315 MHz remote control devices.</i>	
SYMPTOM: No Response	
POSSIBLE CAUSE:	SOLUTION:
Remote control is not programmed	See owner's manual for programming instructions.
Remote control not compatible	Obtain compatible LiftMaster remote control.
Low battery	Replace battery.
SYMPTOM: Remote Cannot Be Learned	
POSSIBLE CAUSE:	SOLUTION:
Low battery	Replace battery.
Remote control not compatible	Obtain compatible LiftMaster remote control.
SYMPTOM: Poor Radio Range	
POSSIBLE CAUSE:	SOLUTION:
Low battery in remote	Replace battery.
Antenna not configured	See owner's manual.
Ambient radio interference or building structural issue	Use EXTERNAL ANTENNA kit (see owner's manual).

The status of a Medium Duty Logic Operator can be determined by counting the number of flashes of the LED on the logic board.

DIAGNOSTIC LED TABLE

# OF LED FLASHES	STATUS	SOLUTION
1	System OK. Operating in C2 mode	None
2	System OK. Operating in B2 mode	None
3	Stuck CLOSE button	Check for stuck close button or shorted close wire
4	LiftMaster Monitored Entrapment Protection Device failure	Check for: 1) Misaligned or blocked Photoelectric Sensors. 2) Issue with Monitored Sensing Edge and/or wiring.
5	Incorrect motor direction	Reverse the yellow and red motor wires on the capacitor.
6	Maximum run timer has timed out (Maximum run time = 90 seconds)	Check clutch adjustment. Door height or speed may exceed the range the operator can travel. Call Technical Support for assistance.
7	Logic board Failure	REPLACE logic board. NOTE: It is normal for the logic board LED to flash 4 times when power is applied or cycled to the operator. (Not a logic board failure.)

RESTRICTED CLOSE

This method will allow the door to be closed when LMEP device(s) are no longer working. Press and hold the CLOSE button until the door reaches the closed limit. If the CLOSE button is released before the door reaches the closed limit the operator will stop and the procedure will need to be repeated to fully close the door.

Requires LiftMaster Monitored Entrapment Protection (LMEP) device. See installation manual for selection and installation of LiftMaster Monitored Entrapment Protection (LMEP) devices.

REMOTE CONTROLS

Built in 315 MHz radio receiver permits as many as 20 Security+® remote controls or dip switch remote controls in any combination.

Single Button Remote Control

- 1) Press and release the LEARN button (LED will light).
- 2) Press and hold the button on the remote control until the LED flashes rapidly, then release to complete programming (LED will go out).

Repeat steps 1 and 2 for additional remote controls.

3-Button Remote Control To Operate As A Wireless 3-Button Control Station

NOTE: The feature will use 3 of the 20 memory channels in the operator.

- 1) Press and release the LEARN button (LED will light).
- 2) Press and release the desired button on the logic board (OPEN, CLOSE or STOP).
- 3) Press and hold the desired button of the remote control until the LED flashes rapidly, then release to complete programming (LED will go out).

Repeat steps 1 through 3 to program additional buttons.

To Erase All Remote Controls

- 1) Press and hold the LEARN button (over 5 seconds) until the LED goes out. All programmed remote controls will be erased.

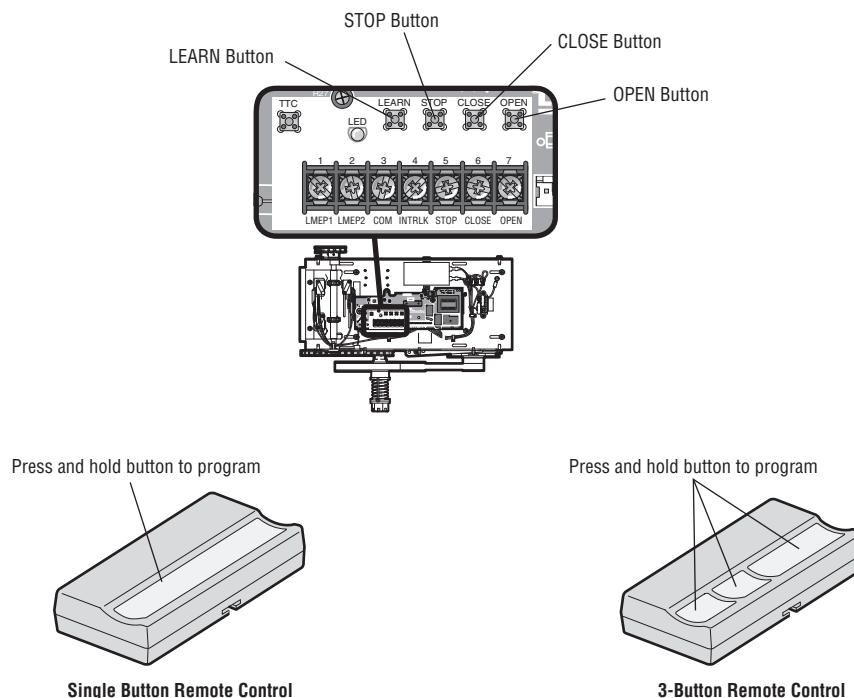

TIMER-TO-CLOSE

Timer-to-Close feature enables the Medium Duty Logic Operator to close from the open limit after a preset time, adjustable from 5 to 60 seconds.

To Program

Begin with the door in a fully closed position.

- 1) Press and release the LEARN button to enter program mode (LED will light).
- 2) Press and release the TTC button.
- 3) Every press and release of the STOP button will add 5 seconds to the Timer-to-Close.
Example: 30 second TTC = 6 presses of the STOP button.
- 4) Press and release the TTC button to exit the programming mode. The LED will flash once per 5 seconds of timer setting.

The TTC will become active after completion of the next open cycle.

NOTE: The LED does not indicate the timer is running.

To Verify The Timer-To-Close (TCC) Setting

- 1) Press and hold the LEARN button (LED will light).
- 2) Press and release the TCC button.
- 3) Press and release the TTC button a second time. The LED will flash once per 5 seconds of timer setting.

Clear The Timer-To-Close (TCC)

- 1) Press and release the LEARN button (LED will light).
- 2) Press and hold the TCC button for 6 seconds.
- 3) Release the TTC button (LED will go out). The TTC will no longer be active.

Timer Defeat

The TTC can be temporarily disabled by pressing a STOP button. TTC will become enabled after the next open command.

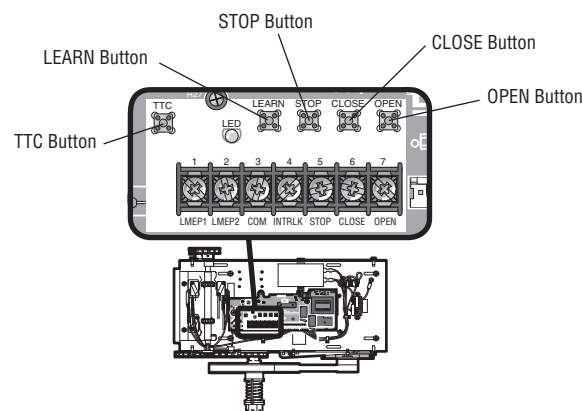

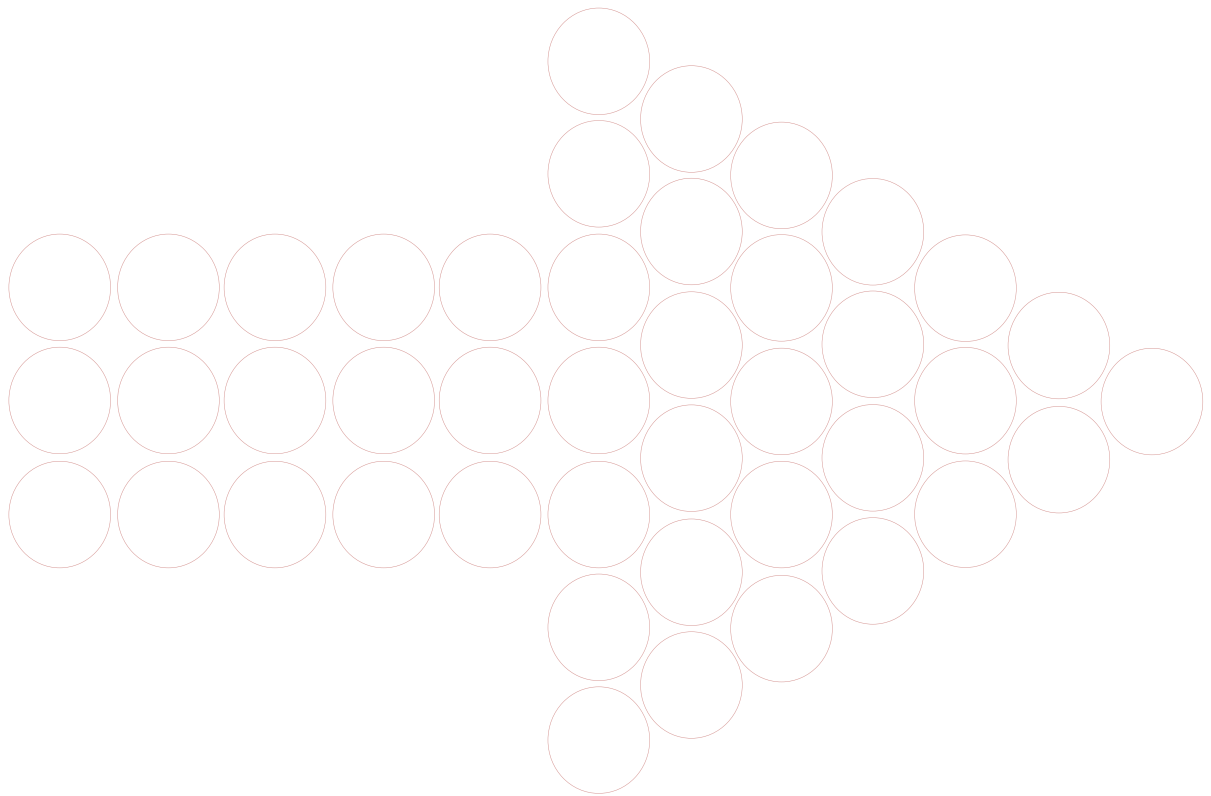

Table of Contents

SECTION C

Mechanical Operators

	Page
Symptoms And Solutions	34

SYMPTOM: The Motor Hums And The Motor Output Shaft Will Not Rotate	
POSSIBLE CAUSE:	SOLUTION:
Brake did not release (if present)	Check the solenoid and check brake adjustment settings.
Door locked or jammed	Check door.
Dead phase	Check the power supply.
Brake may not be disengaging when starting relays energize (if present)	Manually disengage and test again. Repair if needed.
SYMPTOM: Door Will Not Move In Either Direction	
POSSIBLE CAUSE:	SOLUTION:
Clutch is loose	Adjust the clutch.
The pulley V-belt is loose	Adjust belt by adjusting motor position.
The drive chain has broken	Replace drive chain.
Manual disconnect may be engaged	Disengage the disconnect.
SYMPTOM: Door Travels In One Direction Only	
POSSIBLE CAUSE:	SOLUTION:
Bad or miswired limit switch	Test continuity of switches and replace as needed. Verify wiring with schematic provided.
Bad or miswired 3-button control station	Rewire or replace control station.
Open or close relay miswired or defective	Rewire or replace relay.
SYMPTOM: Motor Hums And Starts When It Is Spun	
POSSIBLE CAUSE:	SOLUTION:
Faulty centrifugal start switch (no start switch on 1/3 and 1/2 HP motors using Logic 2.0)	Tap the motor; if it runs now, the centrifugal switch may be faulty – replace the motor.
Faulty capacitor	Replace capacitor.
SYMPTOM: Motor Does Not Hum Or Run In Either Direction	
POSSIBLE CAUSE:	SOLUTION:
Motor thermal overload tripped	Let the motor cool down so internal overload can reset itself, or press the reset depending on model.
Power is not connected properly	Check terminals, circuit breaker, fuses and electrical service panel.
Open and close limit switches are activated	Check limit switches.
Control station wired wrong, or has a stuck button, or auxiliary device is not functioning properly	Check continuity from common to NC prongs. Readjust or replace switches. Remove control stations and auxiliary devices. Test the operator by jumping T4 and T3, then cross T3 and T1 to open T3 and T2 to close. Reattach items one at a time and test operation between each component installation using the component of low-voltage control wires. Replace, repair, or rewire non-working devices.
Bad start switch in motor (single phase only)	Check across black wires on coil of IR relay. Should read same as line voltage.
SYMPTOM: Jackshaft Or Hoist Operator Makes Clicking Noise	
POSSIBLE CAUSE:	SOLUTION:
External interlocks	Interlocks must be “normally closed”. Check switch and wiring.
Miswired motor	Verify the motor is wired correctly
The operator is mounted wrong; the drive sprockets are not in line with the driven sprockets and the chain is clicking	Reposition the operator.

SYMPTOM: Door Drifts After The Operator Is Shut Off	
POSSIBLE CAUSE:	SOLUTION:
Brake needs adjusting (if present)	Check and adjust brake.
Door poorly balanced	Check and adjust door/springs.
SYMPTOM: Door Travels Down And Then Stops And Reverses	
POSSIBLE CAUSE:	SOLUTION:
A sensing device is being activated	Check wiring of the sensing device.
Radio receiver may be sending a long signal to the operator; this can cause the operator to travel down off the open limit, then reverse again	Try disconnecting the receiver. If the problem disappears, use a LiftMaster Brand Receiver
SYMPTOM: Door Opens And Then Stops Short Of The Full Open Position	
POSSIBLE CAUSE:	SOLUTION:
Limit nut not set correctly	Adjust limit nut.
An obstruction may be preventing the proper operation of the door	Check door for obstruction.
The clutch may need adjustment	Check the sensitivity of the clutch.
Defective limit switch activating prematurely	Check limit switch; replace if necessary.
SYMPTOM: Operator Does Not Open Or Close In Response To Command From 3-Button Control Station	
POSSIBLE CAUSE:	SOLUTION:
Bad wire to 3-button control station	Recheck wiring.
Circuit breaker has tripped	Reset circuit breaker.
Damaged transformer	Check transformer and circuit for 24V.
If equipped with electric interlock, there may be a poor contact to the interlock switch	Verify all interlock switches are working correctly and wiring is making good contact.
Blown fuse	Replace fuse.
SYMPTOM: The Door Will Not Close Completely	
POSSIBLE CAUSE:	SOLUTION:
The limit assembly depression plate is not properly engaged with nylon limit nut	Check and adjust if necessary.
The door is binding or meeting an obstruction	Look for obstruction.
Loose drive or limit chain can cause the chain to “jump” the sprocket teeth	Check the chain as necessary. The limit chain can be adjusted/ tensioned at the electrical box assembly via two mounting screws.
SYMPTOM: Motor Runs In Wrong Direction	
POSSIBLE CAUSE:	SOLUTION:
Operator is upside down	For MJ, install operator with motor toward the ceiling. For MT, the electrical box and motor should be toward the floor. Correct if necessary.
Motor is wired incorrectly	Check and correct wiring.
Three-phase wires are in the wrong order	Rearrange any two incoming three-phase power legs on the terminal strip.

Symptoms And Solutions



SYMPTOM: Motor Is Running But The Door Will Not Move	
POSSIBLE CAUSE:	SOLUTION:
The door is obstructed or locked	Check the door
The clutch may need adjustment	Adjust the clutch.
SYMPTOM: Operator Continues To Run At End Of Door Travel	
POSSIBLE CAUSE:	SOLUTION:
Limits are not set correctly	Adjust limits.
Limit switch is faulty	Test the switch and check the switch wiring.
SYMPTOM: Motor Operates In Only One Direction When Operated From Radio	
POSSIBLE CAUSE:	SOLUTION:
Auxiliary device limit switch is not being activated properly	Verify the Auxiliary and Sensing Limit Switches (SLS) are activated in full open and close positions (respectively). Reposition, rewire or replace.
SYMPTOM: Timer To Close Function Is Inoperable	
POSSIBLE CAUSE:	SOLUTION:
Timer to close control station is defective	Test continuity through wire, then repair or replace.
Timer impulse or timer latch relays are defective	Repair or replace.
Timer defeat switch may be activated or miswired	Verify it is “normally closed” and wired correctly; replace if needed.
Defective timer	If timer latch and timer impulse relays activate and timer does not time out, replace timer.
SYMPTOM: Auxiliary Device(s) Will Not Cause Operator To Function Properly (Radio Control, Sensing Edge, Interlocks, Etc.)	
POSSIBLE CAUSE:	SOLUTION:
Incorrect control function settings	Check positions of control wiring for desired wiring type and reset if necessary.
Incorrect electrical wiring connections	Check wiring with diagram; rewire if necessary.
Auxiliary device uses too many watts	If the device is suspect of using too much power, add an additional transformer to power this device.
Auxiliary device limit switch or sensing limit switch is not responding or may be over-running sensing limit switch	Test switches and the timing of the switches.

Table of Contents

SECTION D

Basic Electrical Information

	Page
Basic Electrical Circuit	38
Limit Switches	39
Multimeter	40
Relays	41
Transformers	43

A basic electrical circuit is made up of one continuous electrically conductive loop. As an example, see the wiring diagram of a typical flashlight to the right.

Electricity flows from positive (+) to negative (-). The switch stops the electricity from flowing.

When the switch is closed, electricity will flow in a continuous loop and make the bulb light up. The electricity will flow from the positive side of the battery past the closed switch through the light bulb (providing the electricity to light the bulb) and return to the negative side of the battery.

When the switch is open, the electricity cannot pass through and electrical flow is stopped.

There are many types of switches and components available within an electrical circuit. Examples include: motors, contactors, relays, interlocks, capacitors and limit switches of various types. For commercial operators to function, each component must be working correctly for the electrical flow to pass through and form a continuous electrical circuit or loop.

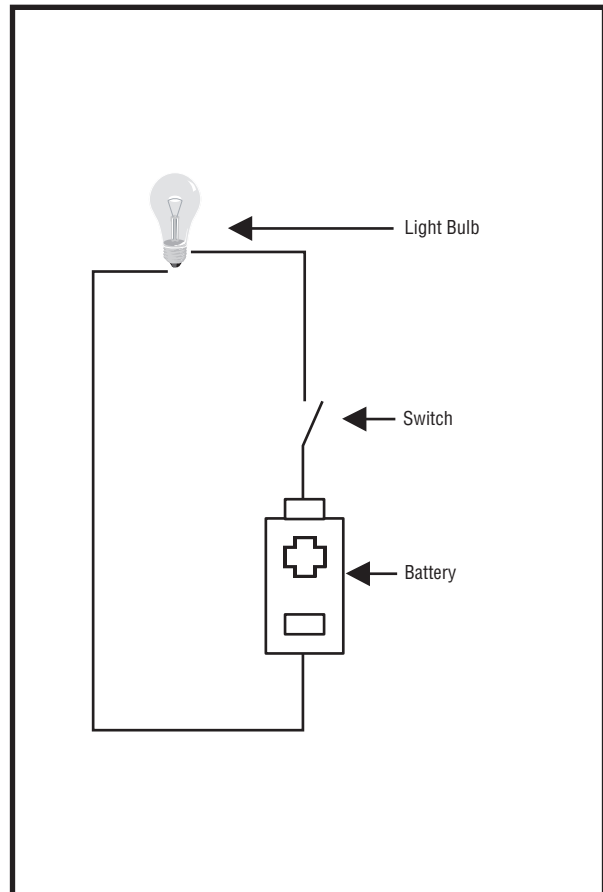

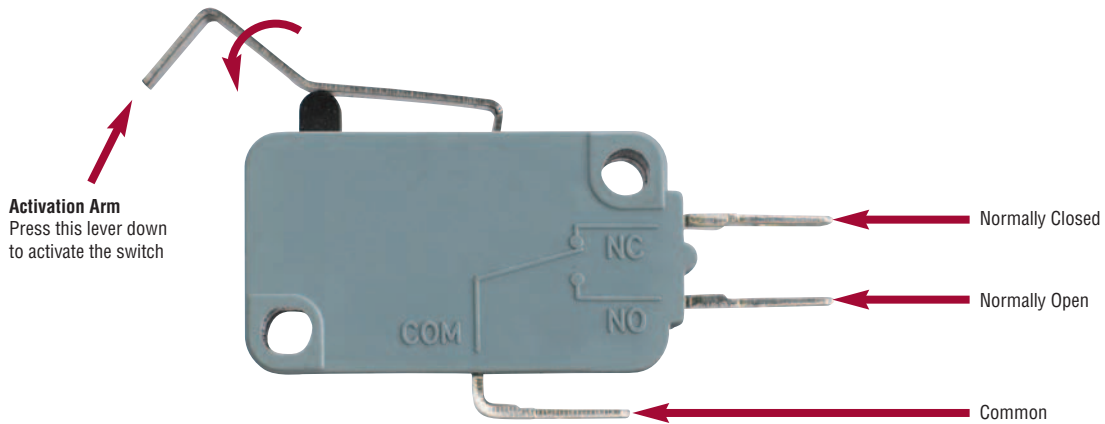

Three prongs are present on a limit switch. They are labeled Common or “Com”; Normally Open, abbreviated NO; and Normally Closed, abbreviated NC. Below is a wire diagram of a limit switch.

When no pressure is applied to the limit switch activation arm, electricity will flow from the Common prong to the Normally Closed prong.

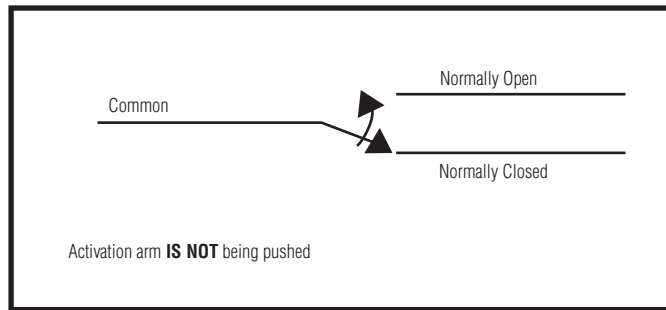

When the activation arm is pressed, electricity will flow from the Common Prong to the Normally Open Prong. Electricity will never travel from the NO prong to the NC prong.

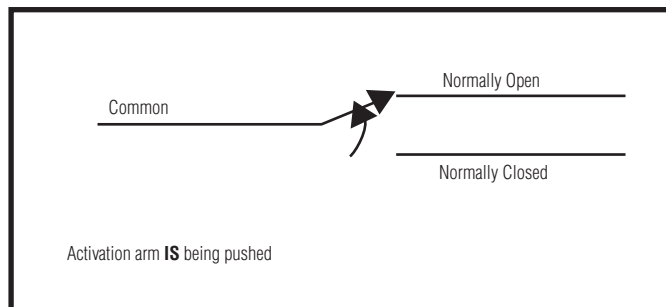

The word “NORMALLY” generally refers to the action of the switch when nothing is activating it. “Normally Closed” is a continuous flow of electricity when the switch is not activated, establishing a closed circuit. “Normally Open” is a non-continuous flow (no flow) of electricity when the switch is not activated, establishing an open circuit.

Below is a photo of a generic multimeter. LiftMaster currently has no intended affiliations with this manufacturer. This is not an endorsement for this particular meter model. When shopping for a meter, look for a meter able to fit in a shirt pocket or clip on a belt. A meter with an audio signal (buzzer) for continuity checks is recommended.



A multimeter and test leads

Checking Ohms/Continuity

When checking the operation of a switch, select the ohm mode on multimeter. (The ohm symbol is Ω). Make sure the test leads are plugged into the correct sockets for reading ohms. If there is more than one setting in the ohm section of the meter, select the one with the audio signal.

To test a limit switch, connect one test lead to the Common prong and the other to the Normally Closed prong. The meter should read 0 resistance or very low resistance. The electricity is flowing from the Common prong to the Normally Closed prong. This demonstrates continuity. Activate the switch, the meter will read infinite resistance or no continuity. The wires inside the switch are no longer touching between the Common prong and the Normally Closed prong.

Move the test lead from Normally Closed to Normally Open. While the activation arm is not pressed, the meter should read open circuit, demonstrating no continuity. Activating the arm should read 0 resistance, demonstrating continuity.

The procedure is called a “Continuity Check” and is used to check for a continuous flow of electricity.

Checking Voltage

A multimeter may have several settings for checking voltages. The number associated with each setting is the maximum voltage able to be read. A meter may be damaged if connected to a higher voltage than selected. Either AC or DC must be selected prior to testing any circuit. AC stands for alternating current and DC stands for direct current. AC is usually the incoming line voltage, i.e. 115VAC, 460VAC and so on. 24VAC is also found in the control circuit of a commercial operator. DC is usually a power source from a battery or the control voltage in a logic board.



Set the meter to VOLTS AC at the lowest setting which is still higher than the expected voltage. If 115VAC is expected and the meter has 10VAC, 50VAC, 250VAC and 1000VAC, turn the dial to 250VAC. Some meters have only one VAC choice and the meter can automatically adjust for the voltage received (auto scaling).

Relays

In commercial operators, relays are often used to either control certain operator functions or activate/deactivate ancillary devices such as heaters or lights.

When electricity is applied to a relay coil, it energizes a magnet and will close a Normally Open switch or open a Normally Closed switch. A relay typically has prongs labeled Comm, NO, NC, and two prongs to power the relay coil. See the light circuit example below containing a relay.

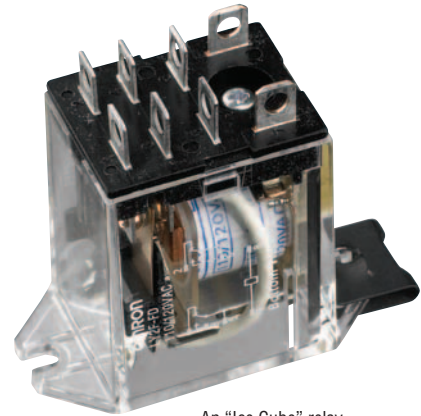

An "Ice Cube" relay

The diagram below shows two different batteries supplying different voltages. The relay separates the electricity so the different components are able to work together. Commercial door operators work in a similar fashion. Relays make it possible for high voltage to work with low voltage.

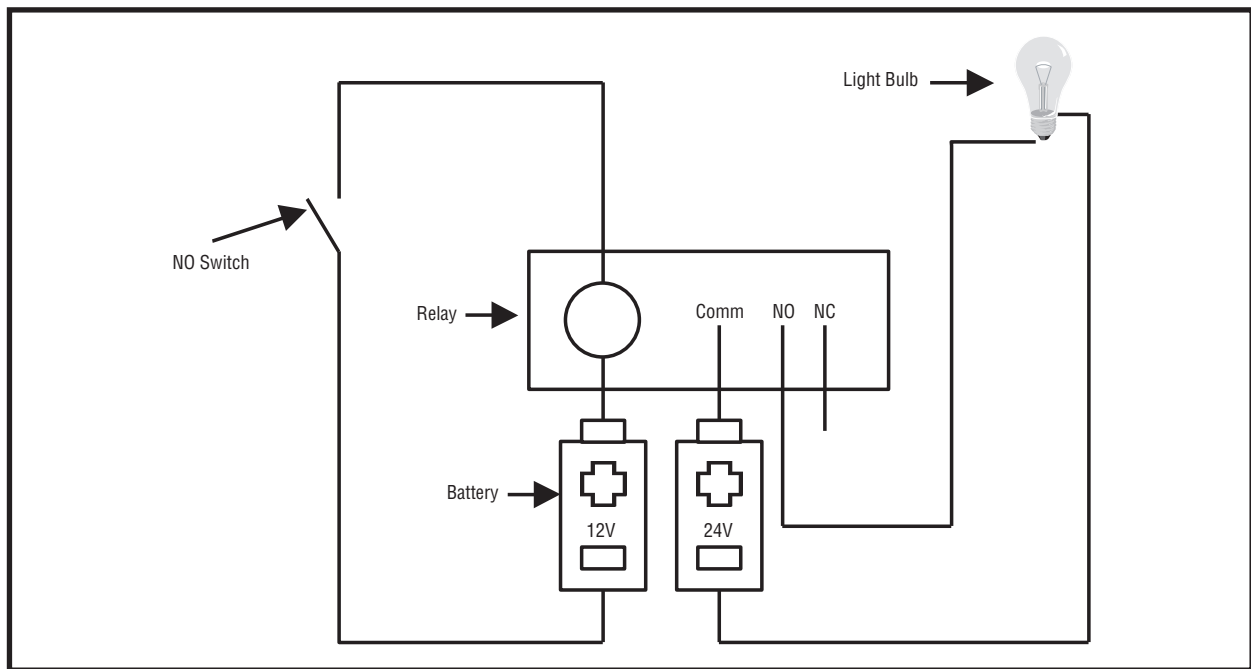

When the NO switch is pressed closed, electricity will travel through the relay coil and activate the relay. The relay switch will allow electricity to flow through the circuit and turn on the light.

Relays are available with different coil voltages and contact options. LiftMaster's line of commercial operators primarily use Double Pole/Double Throw Relays. A pole is another name for a switch. Double Pole is two separate switches being turned on or off by the same activation coil (two separate Comms, NCs and NOs). Double Throw means there are two positions for the output (NO and NC). When shopping for relays, Triple Pole/Single Throw and Single Pole/Double Throw and many other options are available. Relays are rated with specific amp and voltage ratings. Always replace a relay with the same ratings.

When looking at a wiring schematic, relays will be drawn with several components and the name of the relay will be noted.

The Coil

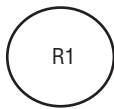

The NO Contacts



The NC Contacts



Here is the same relay light switch shown as a wiring schematic.

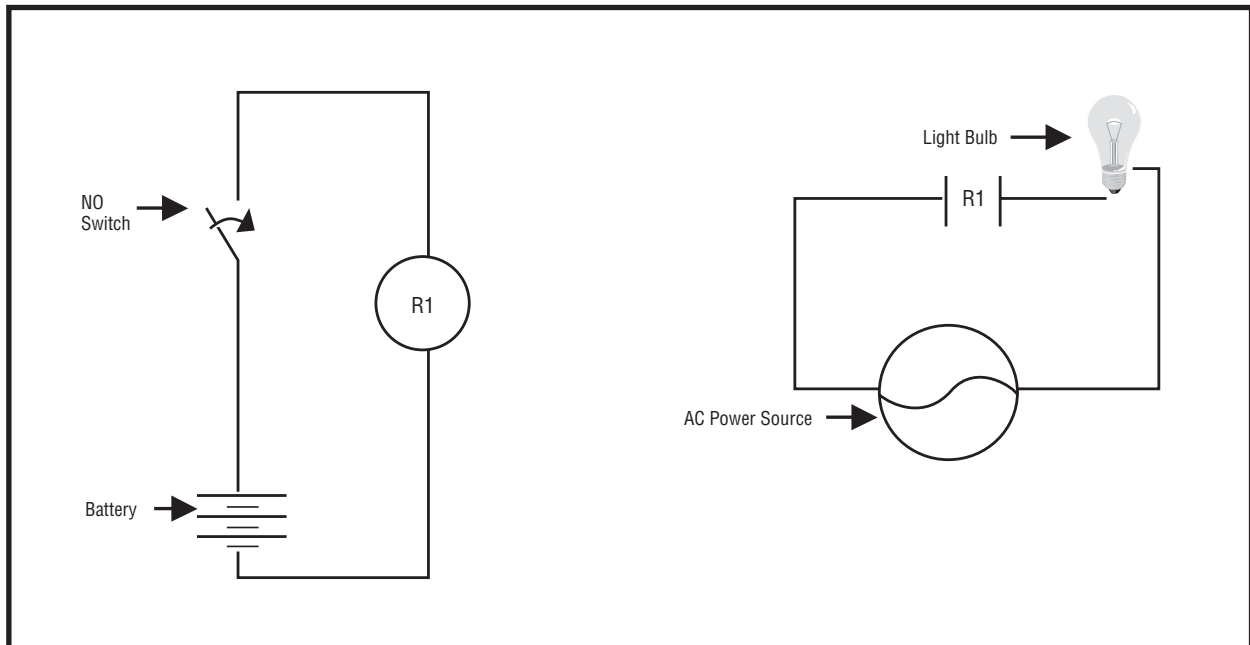

Transformers

Transformers are used to change incoming voltage to a different outgoing voltage. A transformer has a primary side (incoming voltage) and a secondary side (outgoing voltage). The primary side connects to wires from the main power source and the secondary side outputs the new voltage created. In commercial door operators, the secondary side is generally 24VAC. Read the markings on the transformer to determine the primary and secondary voltages.

Transformers are rated in VOLT Amps (VA). A transformer can only pass the rated amount of electricity from the main power to the secondary side. Be careful not to overload the transformer. Verify the amperage rating on all devices connected to the 24VAC side of the transformer including devices attached to the logic board. Multiply the Amperage rating for each device by the voltage needed to run the device.

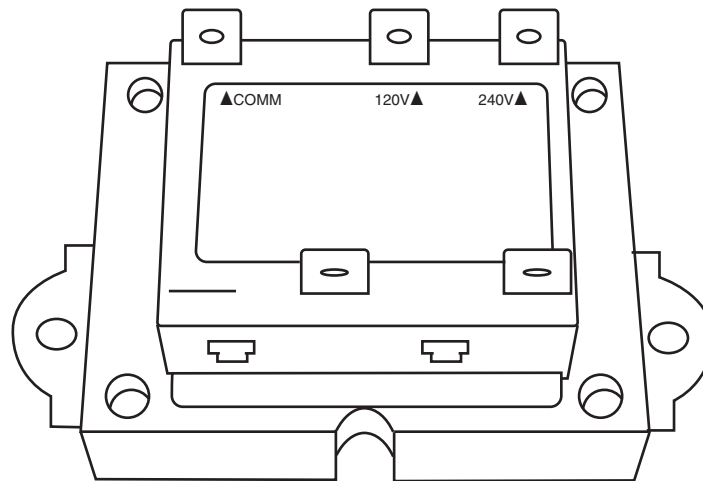

Example for calculating amperage draw:

Below is an example of text for a label that could be placed on accessory devices:

Output Rating...5 AMPS 28VAC or DC Max
Power...24VAC @ 30ma

The “Power” rating is required. The transformer’s secondary side is 24VAC and the transformer is rated for 20VA. The example accessory above uses 30 milli-amps, which is .03 Amps. Multiply the volts being used (24V) and the amps (.03A) to get the VOLT Amps (VA) used by the accessory ($24V \times 0.03A = 0.72VA$). That leaves ($20 - 0.72 =$) 19.28VA left for other accessories (photo-eyes, loop detectors, etc). Once the total VA exceeds 20VA, the operator may experience failures. For operator setups requiring multiple accessories, calculate total VA draw and upgrade the transformer if necessary. (40VA transformers or greater are available).

The output rating is how much electricity the accessory is able to have pass through it. This number is useful when determining if an accessory will properly function long term with the commercial operator. The output rating has nothing to do with the required amount of electricity to make the accessory function.

LiftMaster does offer technical training courses. See the back of this guide or visit liftmastertraining.com for more information.

Table of Contents

SECTION E

General Information

	Page
Frequently Asked Questions	46
Suggested Service Truck Supplies	49
Recommended Wire Gauge Chart	50
Amperage	51

1. **What Are The Minimum Features Required To Be Programmed On A Logic Operator?**
2. **How Is The Maximum Run Timer Feature Set Up?**
3. **What Are The Liftmaster Approved Entrapment Protection Devices?**
4. **How Is The Maintenance Alert System Feature Set Up?**
5. **How Is The Timer To Close Feature Set Up?**
6. **How Is The Mid-Stop Feature Set Up?**
7. **Can The Delay To Reverse Be Changed?**
8. **How Can The Operator Be Set To The Original Factory Default Settings?**
9. **How Can A Second Set Of Photo Eyes Be Installed And What Is Required?**
10. **How To Wire Multiple 3-Button Control Stations.**
11. **What Are The Major Differences Between Logic 4.0 And Logic 5.0?**

1. What Are The Minimum Features Required To Be Programmed On A Logic Operator?

The minimum features required to be programmed include; setting the limits and selector dial for the correct wiring type (C2, B2, etc).

2. How Is The Maximum Run Timer Feature Set Up?

The Maximum Run Timer is a safety feature which allows the operator motor to run in one direction for a limited amount of time. In the event of a door system failure, the operator will not continue to run. The factory default time is ninety seconds. The timer can be set to a user's preference.

To set the Maximum Run Timer:

NOTE: *The default setting for the Maximum Run Timer (MRT) is 90 seconds.*

- Start with the door in the closed position.
- Set the selector dial to PROGRAM.
- Press the MRT button on the logic board.
- Press the OPEN button and wait for the door to reach the full open limit.
- Once the door has reached the open position, programming is complete.
- Turn the selector dial back to desired wiring type.
- Close the door.

NOTE: *To reset the MRT only, turn the selector dial to program and press and hold the MRT button until the MAS LED flashes rapidly.*

3. What Are The Liftmaster Approved Entrapment Protection Devices?

LiftMaster offers a variety of Monitored Entrapment Devices. See page 63.

NOTE: *The CPS3CARD is not compatible with Medium Duty Logic Operators.*

4. How Is The Maintenance Alert System Feature Set Up?

The Maintenance Alert System flashes a light on the control station after a preset number of cycles have occurred to provide an alert for required routine preventative maintenance. The purpose of the system is to promote proper operation of the door through proper maintenance provided by a certified LiftMaster dealer.

To set the MAS:

- Close the door.
- Turn the selector dial to PROGRAM.
- Press and release the MAS button.
- Press the STOP button once to clear the MAS counter.
- Press the OPEN button once for every 5,000 cycle increment. Press the CLOSE button once for every 3-month increment. Press the STOP button once to clear the MAS memory.
- Press the MAS button to complete the programming. The on-board LED will flash back the programmed settings. The OPEN LED will flash once for every 5,000 cycles. The CLOSE LED will flash once for every 3 months.
- Turn the selector dial back to the desired wiring type.

5. How Is The Timer To Close Feature Set Up?

Timer to Close is used to close a door automatically after a preset amount of time has passed.

Logic 3.0

To set the Timer to Close:

- Close the door.
- Turn the selector dial to PROGRAM.
- Press the TIMER button on the logic board.
- Press the STOP button to clear the timer.
- Press the OPEN button for every 5 seconds the operator should wait before attempting to close the door. Press the CLOSE button for every 60 seconds the operator should wait before closing the door.
- Press the TIMER button to complete the programming. The LEDs on the OPEN and CLOSE buttons will flash to confirm the timer setting. The OPEN LED will flash once for every 5 seconds programmed and the CLOSE LED will flash once for every 60 seconds programmed.
- Turn the selector dial to the desired timer wiring type (TS, T or FSTS).

Logic 4.0 / 5.0

- Close the door.
- Turn the selector dial to PROGRAM.
- Press and release the TIMER button on the logic board.
- Press and release the STOP button to clear the timer.
- Press and release the OPEN button for every second the operator should wait before attempting to close the door. Press and release the CLOSE button for every 15 seconds the operator should wait before closing the door.
- Press and release the TIMER button to complete the programming. The LEDs on the OPEN and CLOSE buttons will flash to confirm the timer setting. The OPEN LED will flash once for every second programmed and the CLOSE LED will flash once for every 15 seconds programmed.
- Turn the selector dial to the desired timer wiring type (TS ,T or FSTS).

6. How Is The Mid-Stop Feature Set Up?

Mid-Stop is used when the door is not required to open fully on every cycle. Mid-Stop will stop the door at a preset height during the open cycle.

To set the Mid-Stop:

- Close the door.
- Turn selector dial to PROGRAM.
- Press and release the MID button on the logic board.
- Press the OPEN button. When the door reaches the desired mid-stop height, press and release the STOP button.
- Press and release the MID button to complete the programming.
- Turn the selector dial to the desired wiring type.

7. Can The Delay To Reverse Be Changed?

On a Logic Operator, the delay to reverse is preset at 1.5 seconds and is not able to be changed. This length of time has been determined as appropriate to allow the door to reverse without jerking on the operator and door parts, which may cause premature failure of the operator and/or door.

8. How Can The Operator Be Set To The Original Factory Default Settings?

To reset most of the user-installed settings back to factory defaults:

- Turn the selector dial to DIAGNOSTIC.
- Press and hold the STOP button for 5 seconds. The MAS LED will flash momentarily when the factory defaults have been restored.
- Return the selector dial to the desired wiring type.

Factory Defaults:

- Timer to Close = 0 seconds
- Monitored Entrapment Protection Device (CPS-U Photo Eye or OES Edge) = unlearned
- Mid-Stop = deactivated
- Maintenance Alert System = deactivated
- Maximum Run Timer = 90 seconds

9. How Can A Second Set Of Photo Eyes Be Installed And What Is Required?

Installing a second set of photo eyes on a Logic 3.0, 4.0 or 5.0 operator requires the use of a CPS3CARD. The first set of photo eyes will wire to LMEP and COMMON on the logic board. The second set will wire to the CPS3CARD. The card is plugged into the logic board.

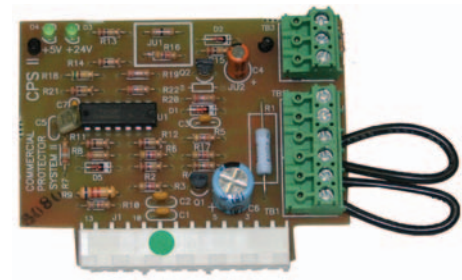

10. How To Wire Multiple 3-Button Control Stations.

WIRING TWO 3-BUTTON CONTROL STATIONS

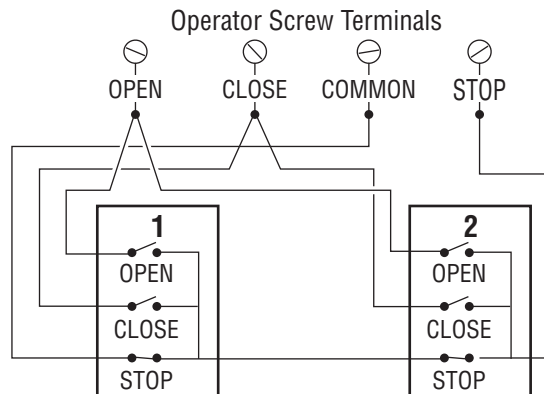

The STOP Circuit must be wired in series.
The OPEN and CLOSE wiring should be in parallel.

11. What Are The Major Differences Between Logic 4.0 And Logic 5.0?

Exclusive Logic 5.0 Features:

- MyQ® Technology - Internet connectivity for monitoring and controlling a commercial door operator from a smart phone, tablet or computer.
- Security + 2.0™ On Board Receiver - Improves range and reduces radio interference.
- Dual Voltage - Within phases, voltage is selectable at the time of installation with the placement of a connector. Single-phase is compatible with 115v and 230v. 3-phase is compatible with 208v, 230v and 460v. 3-phase, 575v is a model without field selectable voltage.

Suggested Service Truck Supplies



General Information

The items listed below are intended for repair of a LiftMaster operator and not necessarily for repair of a door.

MULTIMETER - Look for a meter that has an audio signal for continuity. To make working on a ladder safer and easier, look for test leads able to grip onto the wire being tested. A high quality (expensive) multimeter is not required. A less expensive meter will work very well for diagnosing electrical issues within an operator.

SCREWDRIVERS - Standard size Phillips and Flathead and a small size Flathead for setting DIP switches and working with Logic "Daughter Boards" i.e. CPS3CARD, TLS1CARD, etc. Screwdrivers should be insulated.

SOCKETS AND CRESCENT WRENCHES - A 1/4" nut driver will be extremely handy. Crescent Wrenches and Socket Sets are mainly for removing an operator from the door, wall or ceiling.

Additional Items:

Wire Stripper w/Crimping Tool
Wire Cutters
Needle Nose Pliers
Standard Pliers
Manual Winch - Used for lifting or lowering the operator safely
Jumper Wires w/Alligator Clips

Spare Parts To Keep On The Truck:

16AWG Stranded Insulated Wire
(at least 5 colors)

Limit Switches
(including at least one aux. limit switch kit)

CPS-U Entrapment Device

Edge Kit and Replacement Components

Sprocket Keys and Setscrews

Logic Operators:

Replacement boards:
Logic 4.0
Logic 5.0
RPM Sensor
Logic 5.0 Power Boards
(single-phase and 3-phase)
Medium Duty Logic Board

Belt
Chain
Stripper w/Crimping Tool
40VA Transformers
Relays
Master Link
3-Button Control Station
893MAX Remote Control

Mechanical Operators:

Contactors
Belt
Transformers
Relays
Master Link

Recommended Wire Gauge Chart



General Information

Recommended Control Wire Gauge Based On Wire Run Length For Mechanical Operators

Logic Operators are rated for up to 1000 feet with 18-gauge wire.

Wire Gauge (AWG)	Control Wire Distance	
	MECHANICAL	LOGIC
	Feet	Feet
22	N/A	600
20	50	700
18	75	1000
16	115	
14	180	
12	290	
10	500	

NOTES:

- 1) These distances are for accessory wires such as 3-button control stations, photo-eyes, loop detectors and treadle hoses.
- 2) The control distance is the distance between the power connection and the accessory in question.
e.g. a 3-button control station 25 feet from the operator
a loop detector 30 feet from the operator
photo-eyes 10 feet from the operator

Main Power Wire Gauge And Length Recommendations

A power drop between idle (off) and running voltage should not exceed 2 volts.

Understand the amperage rating for each operator's voltage and horsepower using Table 1. The information in the table may change without notice; review the instruction manual provided with each operator for the most current information.

Determine the gauge of wire needed to safely accommodate the distance between the operator and the electrical box using either Table 2A for SINGLE PHASE or 2B for THREE PHASE (page 51).

NOTE: The amount of electricity carried by a wire is restricted to the release of heat through the electrical insulation material (the cable insulation can melt if the improper gauge is used).

TABLE 1 Amperage By Model/Horsepower And Voltage (All Voltages Are 60Hz)

Model	HP	115V	230V 1ph	230V 3ph	460V	575V
LGJ	1/2	5				
ATS	1/4	5				
MGJ	1/2	6		2.1	1.1	
MT, MJ & MH	1/2	6				
APT	1/2	11.2				
T, J, H, DJ, DH & SD	1/3	8.5	4.2	3	1.5	1.3
T, J, H, DJ, DH & SD	1/2	11.2	5.6	3.1	1.75	1.4
T, J, H & SD	3/4	13.6	6.8	4	2	1.6
T, J, H & SD	1	16	8	6	3	1.8
GT	1/2	11.2	5.6	3.1	1.75	1.4
GT	3/4	13.6	6.8	4	2	1.6
GT	1	16	8	6	3	1.8
GT	1-1/2	20	10	7	3.5	2.75
GH & GSD	1/2	11.2	5.6	3.1	1.75	1.4
GH & GSD	3/4	13.6	6.8	4	2	1.6
GH & GSD	1	16	8	6	3	1.8
GH & GSD	1-1/2	20	10	7	3.5	2.75
GH	2			8	4	3
GH	3			10.6	4.8	

TABLE 2A SINGLE-PHASE OPERATORS/Wire Needed For Distance Between Operator And Electrical Box

Amps	50 FT	100 FT	200 FT	350 FT	500 FT	750 FT	1000 FT
12	12	8	6	4	2	0	
11	12	10	6	4	2	1	0
10	12	10	6	4	2	1	0
9	12	10	6	4	2	2	0
8	14	10	8	6	4	2	1
7	14	12	8	6	4	2	2
6	14	12	8	6	4	2	2
5	16	12	10	8	6	4	2
4	16	14	10	8	6	4	4
3	18	14	12	10	8	6	4
2	20	16	14	12	10	8	6
1	22	20	16	14	12	10	10

TABLE 2B THREE-PHASE OPERATORS/Wire Needed For Distance Between Operator And Electrical Box

Amps	50 FT	100 FT	200 FT	350 FT	500 FT	750 FT	1000 FT
12	8	6	2	1			
11	10	6	4	1	0		
10	10	6	4	2	0		
9	10	6	4	2	0		
8	10	8	4	2	1		
7	12	8	6	2	2	0	
6	12	8	6	4	2	0	
5	12	10	6	4	2	1	0
4	14	10	8	6	4	2	1
3	14	12	8	6	4	2	2
2	16	14	10	8	6	4	4
1	20	16	14	12	10	8	6

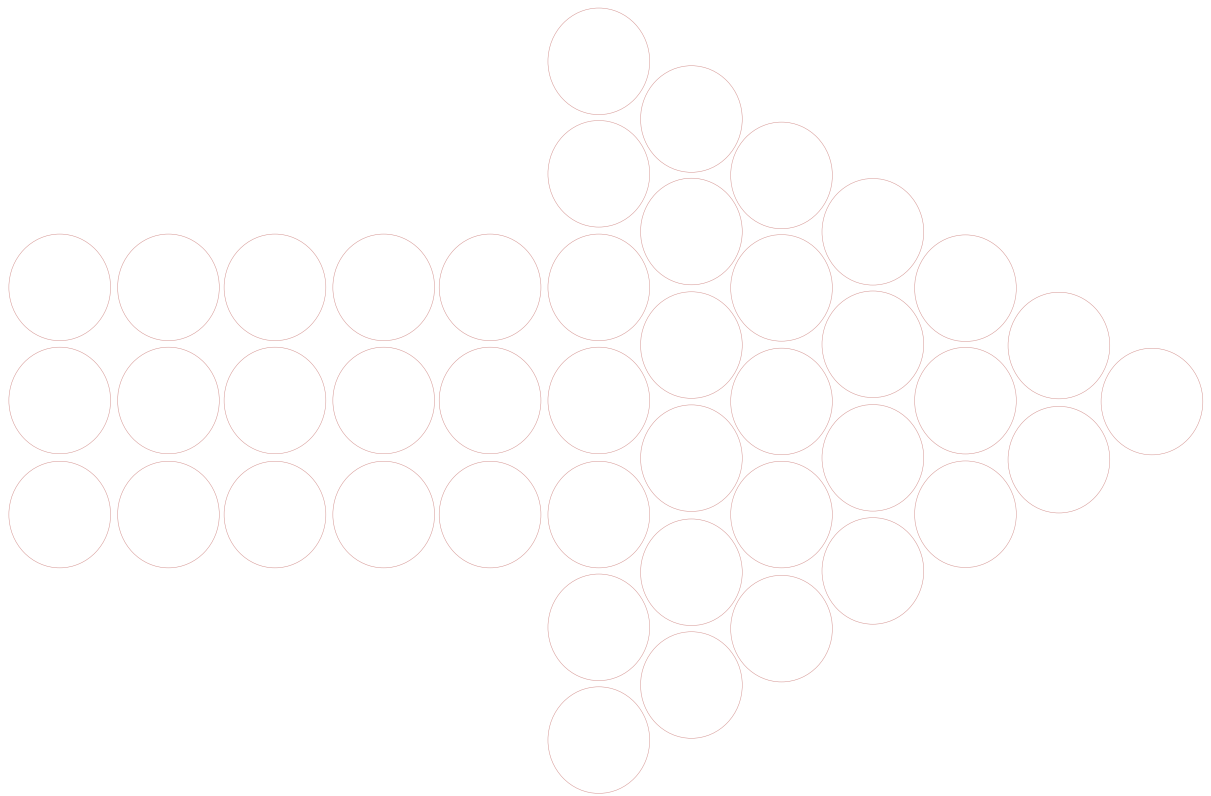

Table of Contents

SECTION F

Wiring Diagrams

	Page
Logic 5.0 - Single Phase	54
Logic 5.0 - Three Phase	55
Logic 4.0 - Single Phase	56
Logic 4.0 - Three Phase	57
Logic 3.0 - Single Phase	58
Logic 3.0 - Three Phase	59
Medium Duty Logic Operator	60
Mechanical Operator - Single Phase	61
Mechanical Operator - Three Phase	62

Logic 5.0 - Single Phase



Wiring Diagrams

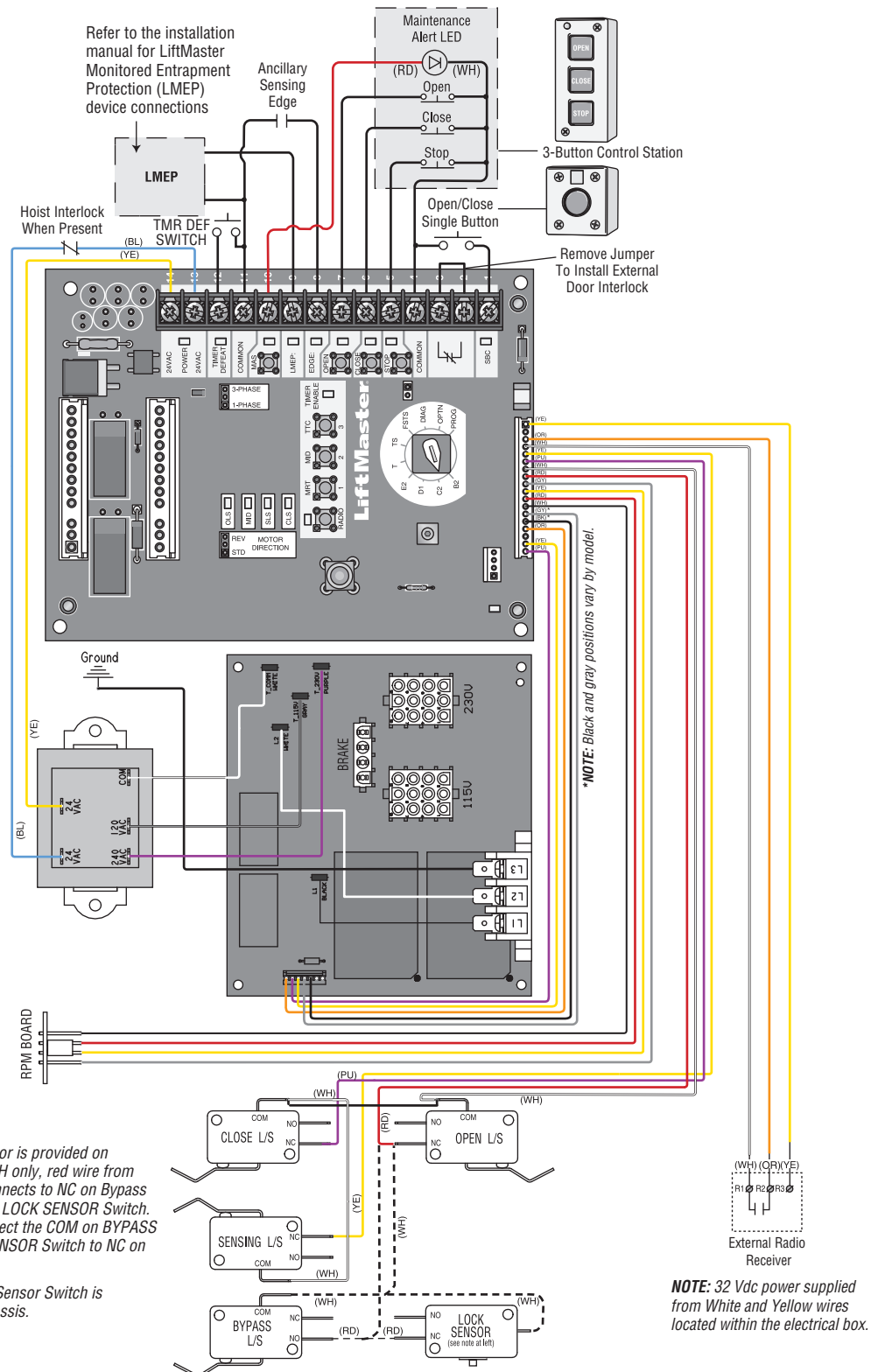

Logic 5.0 - Three Phase



Wiring Diagrams

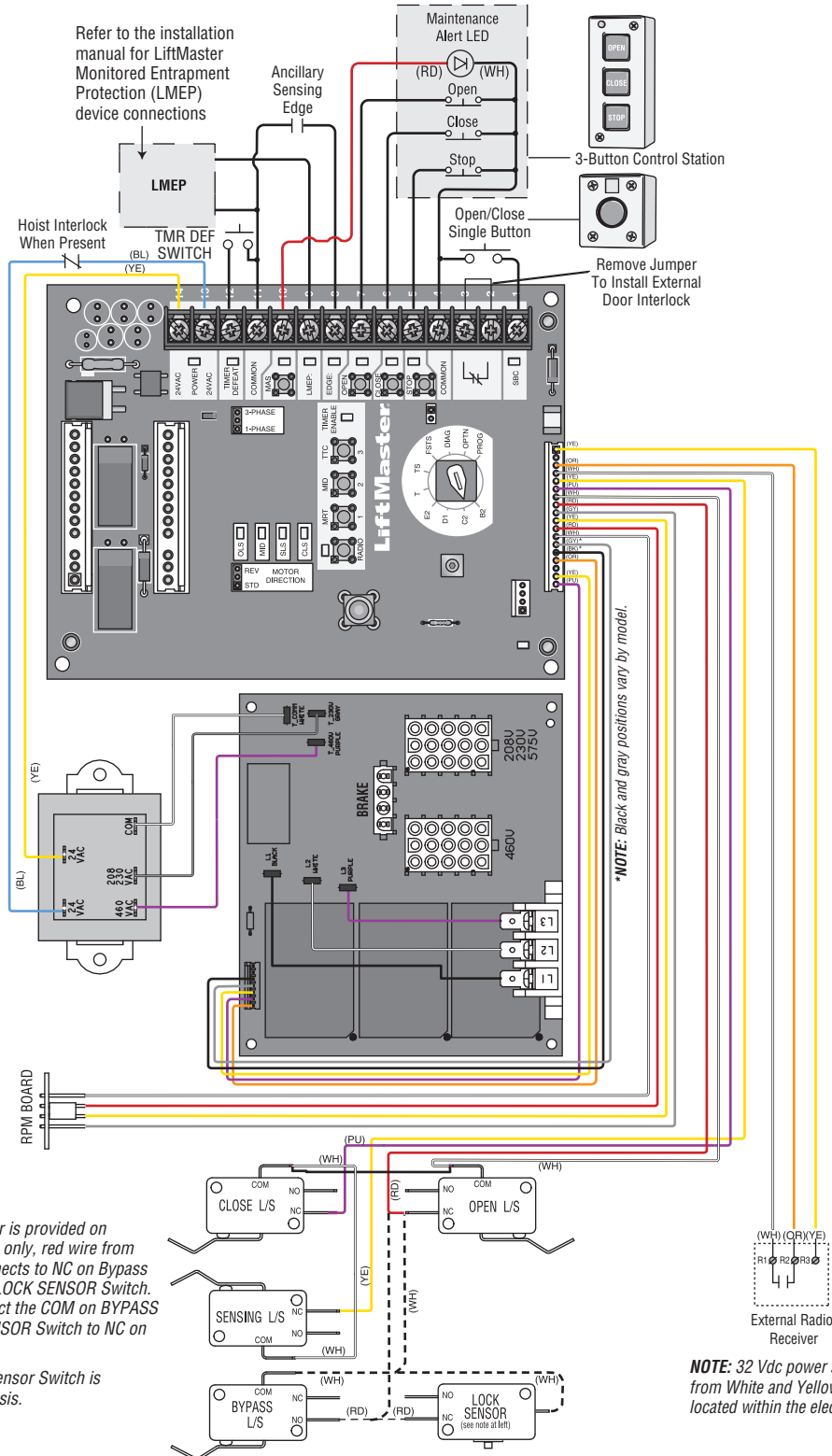

NOTE: Lock Sensor is provided on Models DJ and DH only, red wire from main harness connects to NC on Bypass L/S and to NO on LOCK SENSOR Switch. White wires connect the COM on BYPASS L/S and LOCK SENSOR Switch to NC on Open L/S.

NOTE: The Lock Sensor Switch is located in the chassis.

NOTE: 32 Vdc power supplied from White and Yellow wires located within the electrical box.

Logic 4.0 - Single Phase

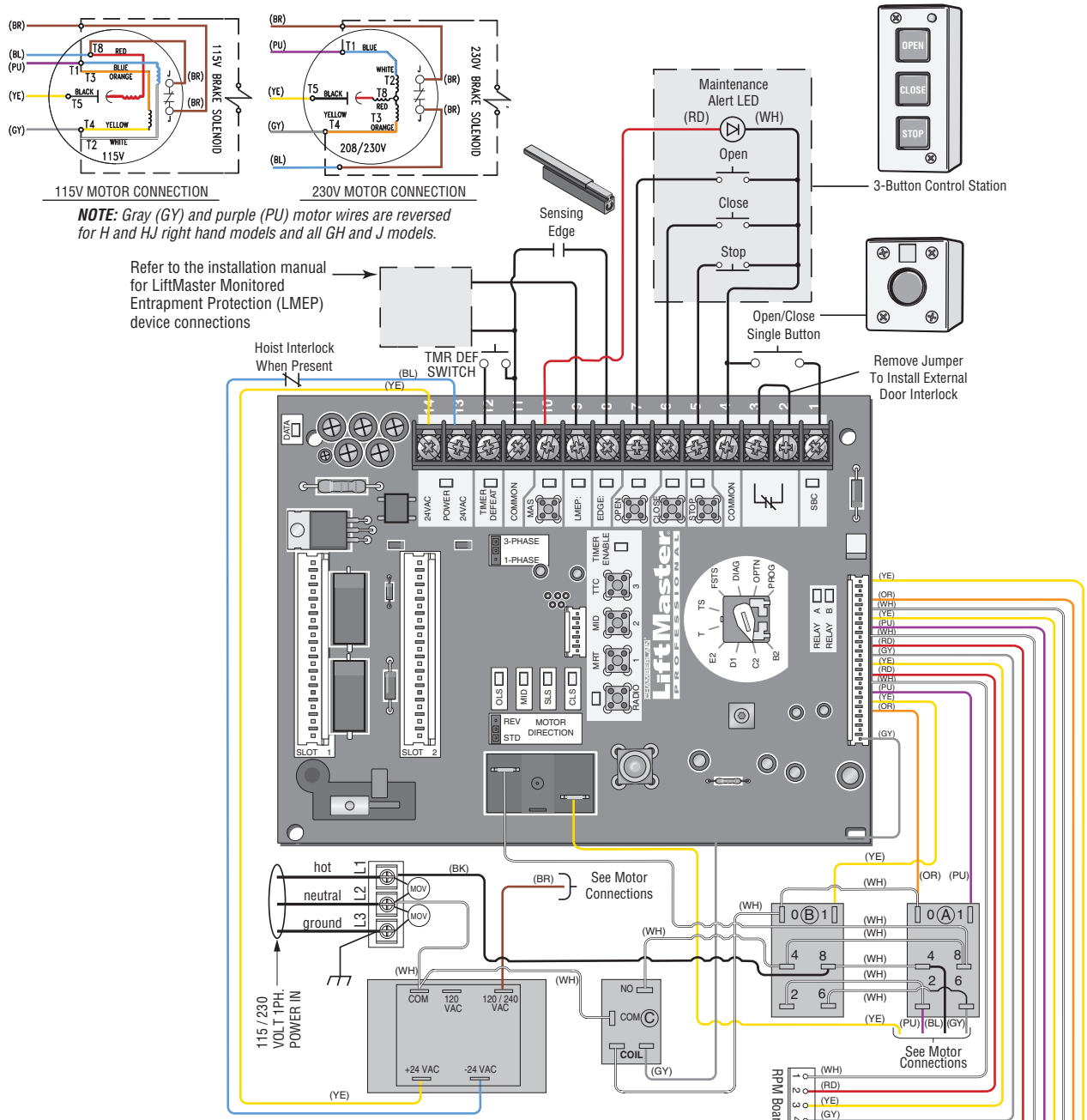

NOTE: Lock Sensor is provided on Models DJ and DH only, red wire from main harness connects to NC on Bypass L/S and to NO on LOCK SENSOR Switch. White wires connect the COM on BYPASS L/S and LOCK SENSOR Switch to NC on Open L/S.

NOTE: The Lock Sensor Switch is located in the chassis.

NOTE: 32 Vdc power supplied from White and Yellow wires located within the electrical box.

Logic 4.0 - Three Phase



Wiring Diagrams

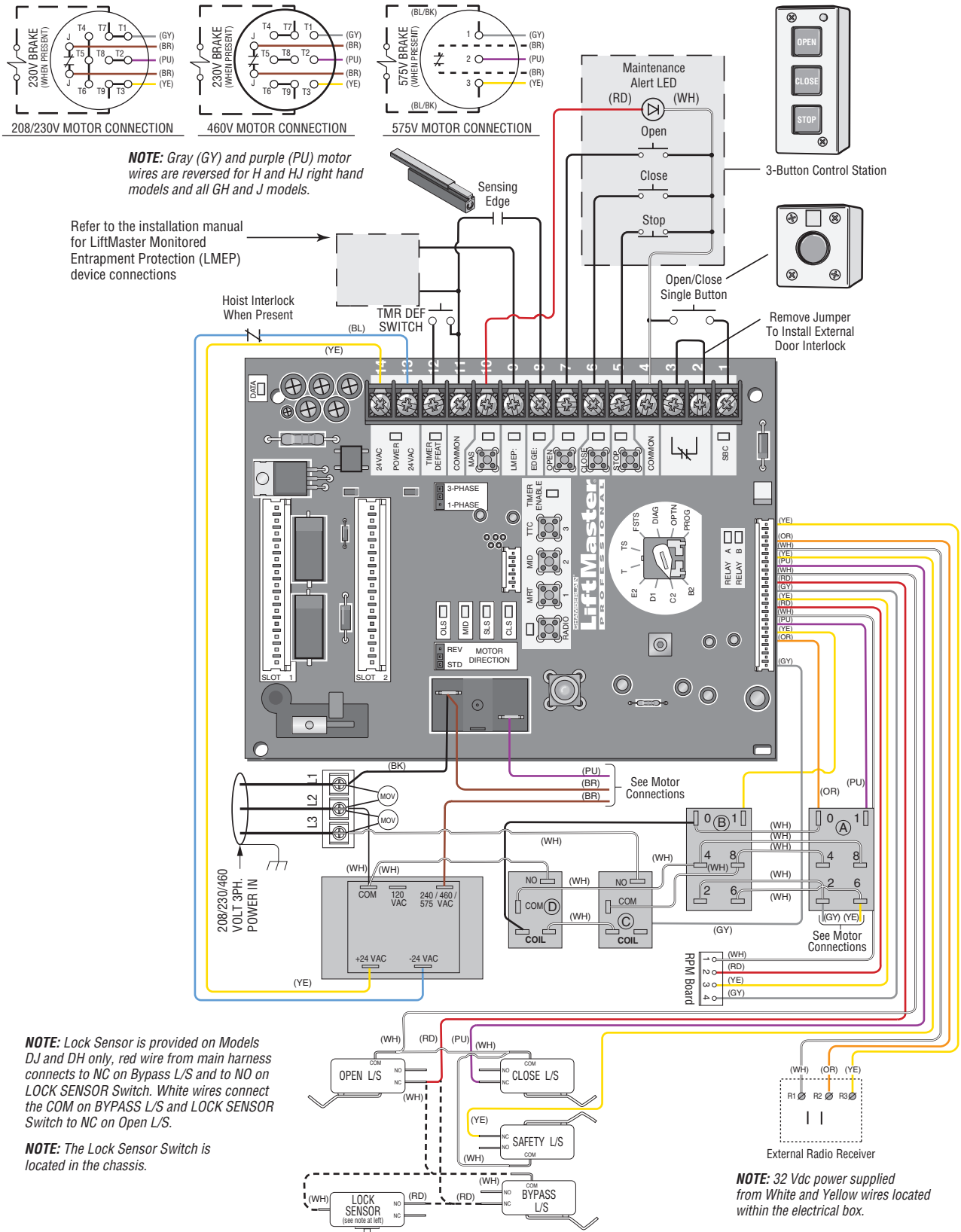

Logic 3.0 - Single Phase



Wiring Diagrams

NOTE: Gray (GY) and purple (PU) motor wires are reversed for H and HJ right hand models and all GH and J models.

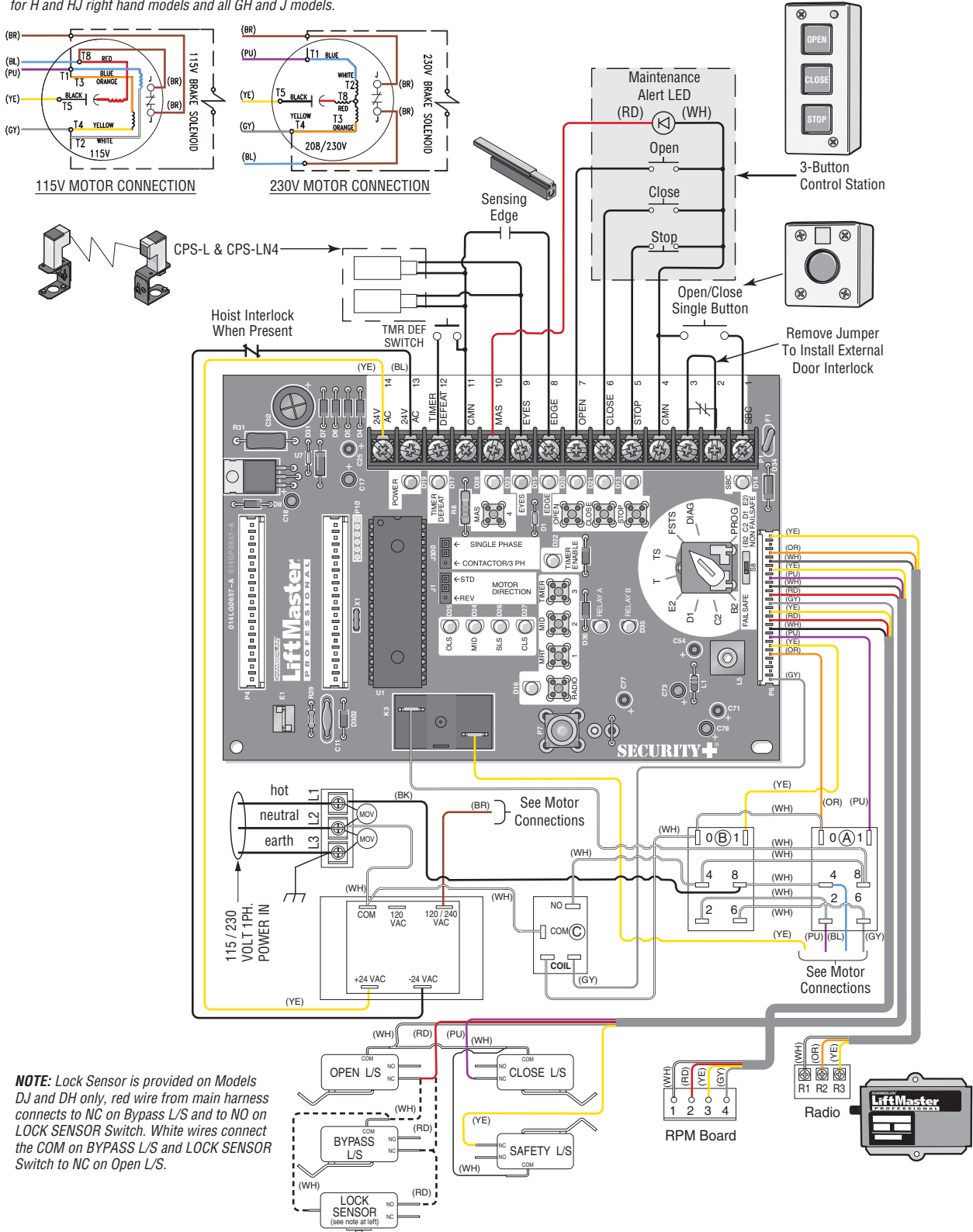

NOTE: Lock Sensor is provided on Models DJ and DH only, red wire from main harness connects to NC on Bypass L/S and to NO on LOCK SENSOR Switch. White wires connect the COM on BYPASS L/S and LOCK SENSOR Switch to NC on Open L/S.

Logic 3.0 - Three Phase

NOTE: Gray (GY) and purple (PU) motor wires are reversed for H and HJ right hand models and all GH and J models.

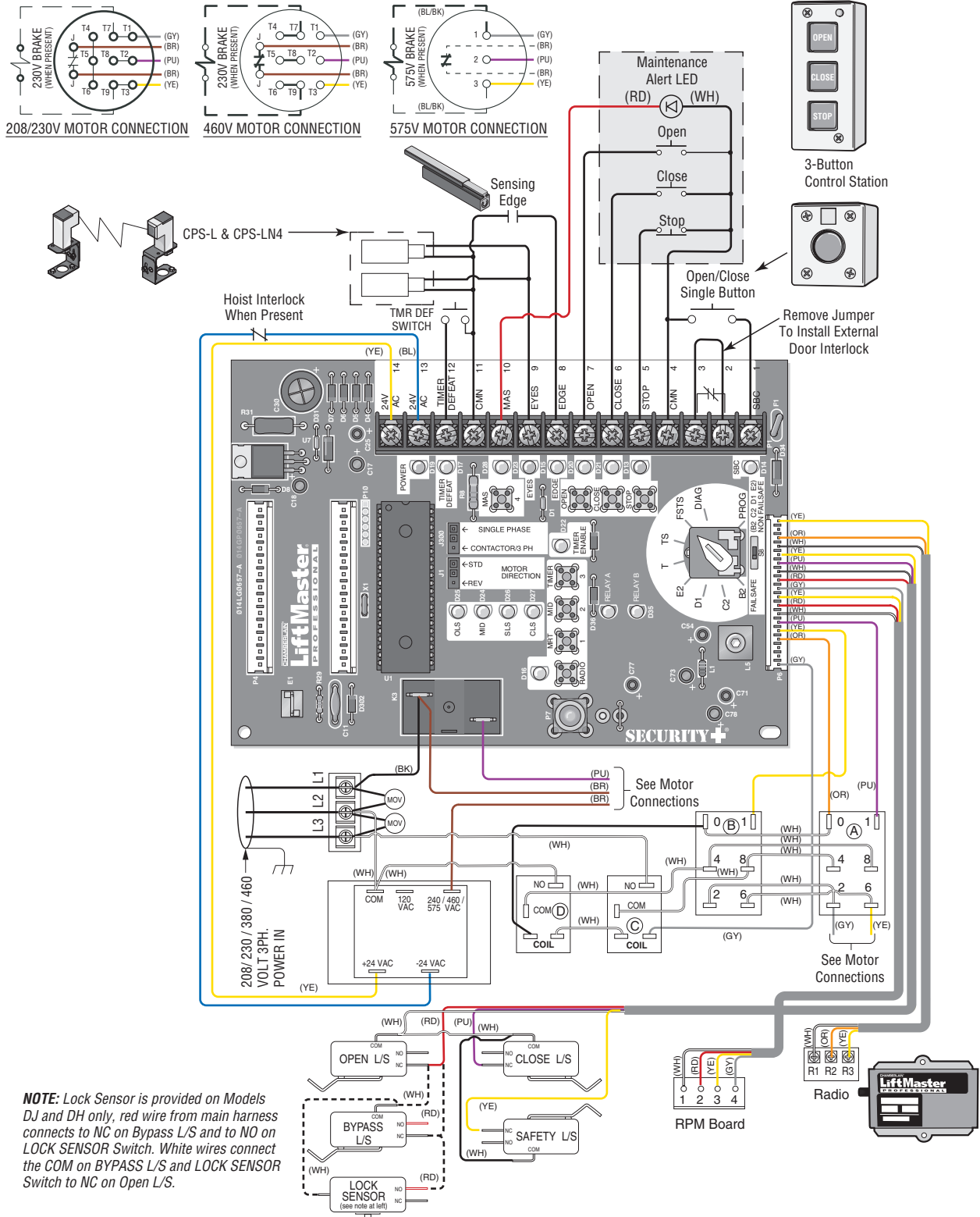

NOTE: Lock Sensor is provided on Models DJ and DH only, red wire from main harness connects to NC on Bypass L/S and to NO on LOCK SENSOR Switch. White wires connect the COM on BYPASS L/S and LOCK SENSOR Switch to NC on Open L/S.

Medium Duty Logic Operator



Wiring Diagrams

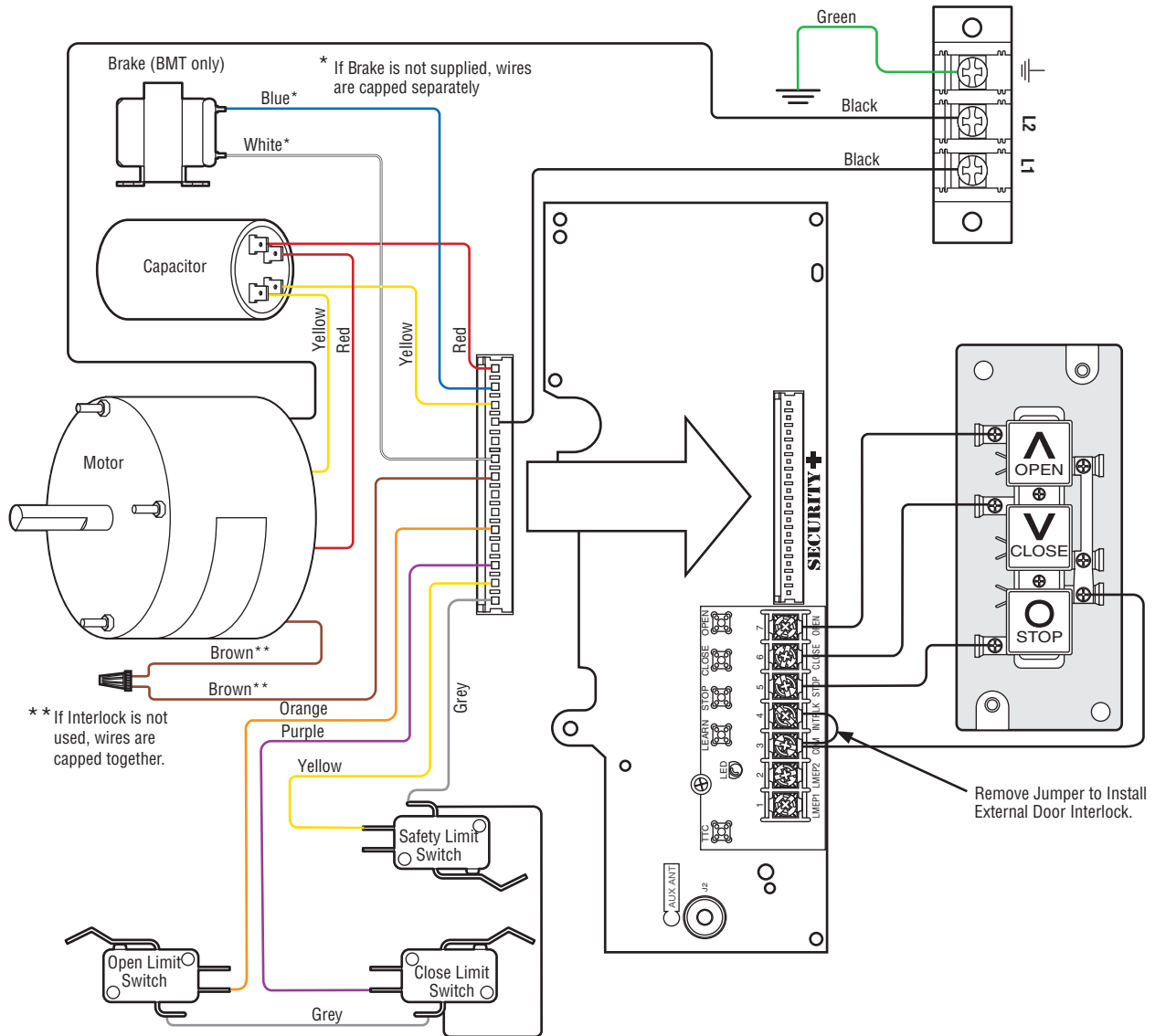

26

Mechanical Operator - Single Phase



Wiring Diagrams

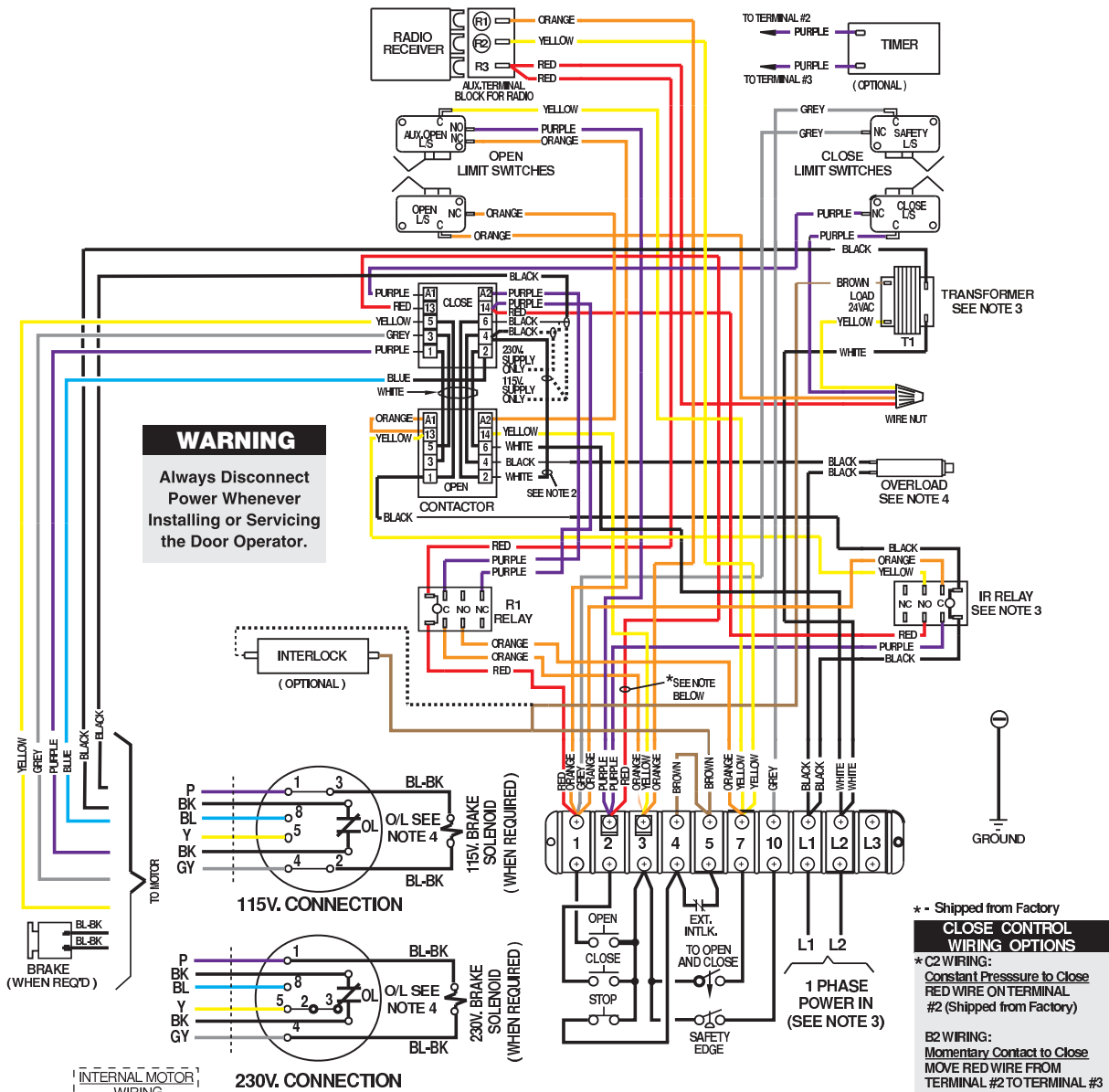

WARNING
Always Disconnect Power Whenever Installing or Servicing the Door Operator.

* - Shipped from Factory
CLOSE CONTROL WIRING OPTIONS
* C2 WIRING:
Constant Pressure to Close
RED WIRE ON TERMINAL #2 (Shipped from Factory)
B2 WIRING:
Momentary Contact to Close
MOVE RED WIRE FROM TERMINAL #2 TO TERMINAL #3

INTERNAL MOTOR WIRING
1 - BLUE
2 - WHITE
3 - ORANGE
4 - YELLOW
5 - BLACK
8 - RED
O/L - BROWN

- NOTES:
- 1) TO REVERSE MOTOR DIRECTION: INTERCHANGE PURPLE & GRAY MOTOR LEADS AT CONTACTOR 1 & 3.
 - 2) WIRE MUST BE REMOVED FOR 230V 1PH OPERATION.
 - 3) TRANSFORMER PRIMARY & RELAY VOLTAGE SAME AS LINE VOLTAGE.
 - 4) SINGLE PHASE UNITS ARE EQUIPPED WITH AN EXTERNAL LINE BREAK DEVICE, AND MAY BE EQUIPPED WITH AN ADDITIONAL INTERNAL PILOT DUTY THERMAL O/L DEVICE.

Mechanical Operator - Three Phase

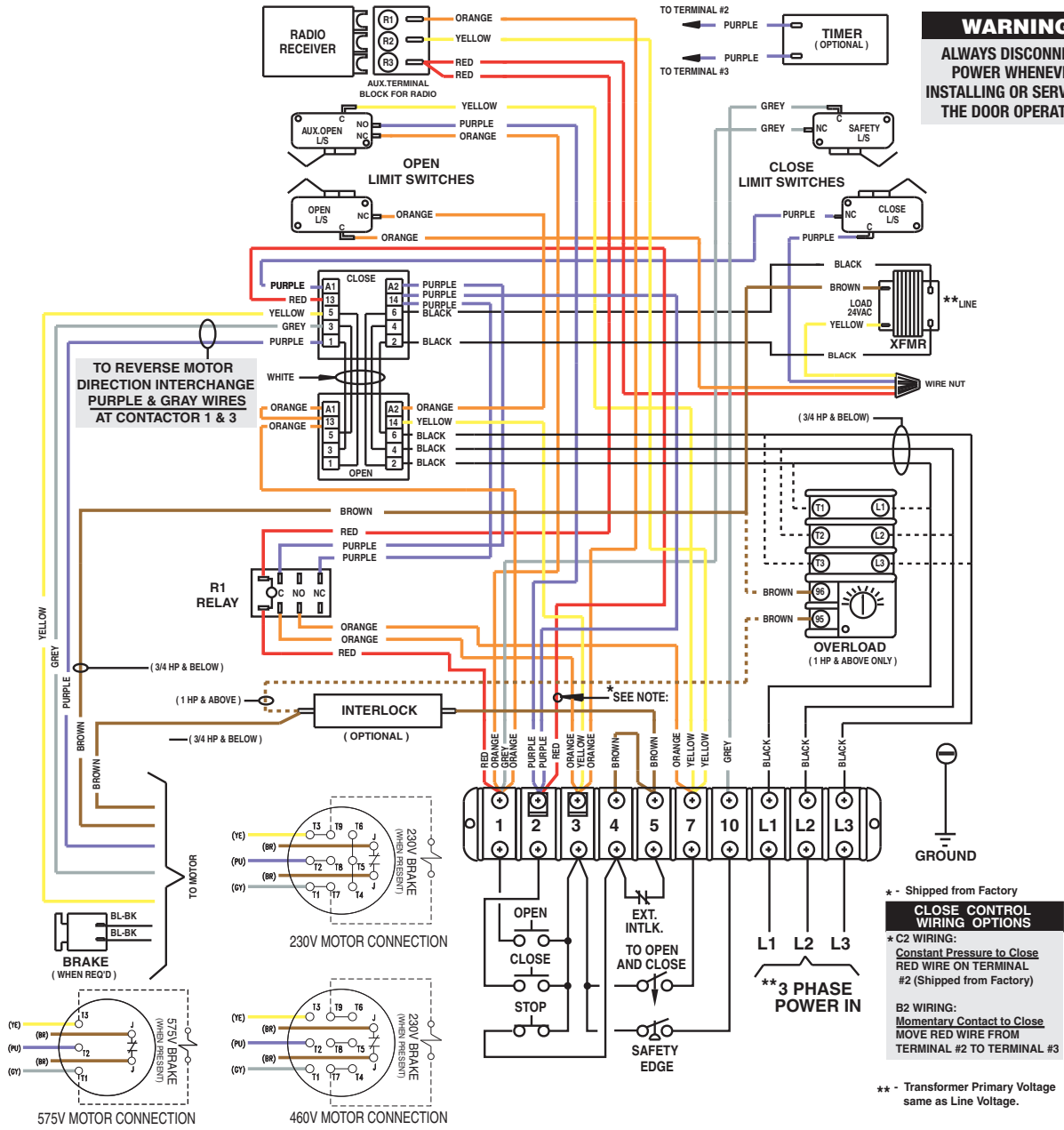

Commercial Door Entrapment Protection Systems

MONITORED PHOTO EYES

CPS-UN4



- Heavy-duty housing for industrial applications
- NEMA 4 enclosure protects against direct spray
- Dual-sided infrared sensors
- For indoor/outdoor use
- Maximum range of 45 feet

CPS-OPEN4



- Flexible housings maintain alignment in areas with a high propensity for sensor contact
- NEMA 4X enclosure protects against direct water spray and corrosion
- Dual-sided infrared sensors
- For indoor/outdoor use
- Maximum range of 45 feet

CPS-RPEN4



- Polarized beam for use in applications with highly reflective surfaces
- NEMA 4X enclosure protects against direct water spray and corrosion
- Retro-reflective sensor
- For indoor/outdoor use
- Maximum range of 50 feet

CPS-U



- NEMA 1 general purpose enclosure
- Dual-sided infrared sensors
- For indoor use
- Maximum range of 30 feet

SAFETY INTERFACE

CPS3CARD



- Additional interface card for adding a second set of monitored photo eyes or a monitored edge to a door opening
- For extra door protection

MONITORED OPTICAL EDGE SYSTEM

OES-SD16 OES-SD24 OES-RD16



- Rubber door edge is durable, flexible and easy to install • Premium rubber can be cut to length for exact fit
- NEMA 6 rating protects against moisture and standing water
- Infrared optical sensors eliminate the need for electrical contacts
- Maximum range of 33 feet

Sectional and rolling door edges are also available in 50' bulk rolls, along with individual components for additional savings on large installation jobs.

OPTICAL EDGE SYSTEM ACCESSORIES

OES-SD50



Rubber Sectional Door Edge

50' roll of quality rubber sectional door edge is the most cost effective option for multiple installations.

OES-RD50



Rubber Rolling Door Edge

50' roll of quality rubber rolling door edge is the most cost effective option for multiple installations.

OES-EDSR



Optical Edge Sensor Kit

Kit includes infrared transmitter and receiver.

OES-JBOX



Junction Box

Enables the connection between the operator and the edge.

OES-COIL



2-Wire Coil Cord

Provides a flexible connection from the junction box to operator or switch.

OES-COND



Conduit Installation Kit

Eliminates the need for electrical conduit installation and includes junction boxes and cables.

OES-DECK



Sectional Door Mounting Kit

Secures rubber edge to the door.

OES-RDCK

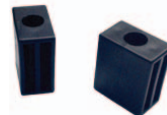

Rolling Door Mounting Kit

Secures rubber edge to the door.

OES-4504

1-3/4" x 1-3/4" PVC Channel

Connects the door to the edge kit. 16' total (sectional door only).

OES-5104

2" x 2" PVC Channel

Connects the door to the edge kit. 16' total (sectional door only).

Contact your LiftMaster Sales Representative at 800.282.6225 or visit LiftMaster.com

TO PLACE AN ORDER

Online

dealer.liftmaster.com

Phone

800-528-2806

ADVANCED TECHNICAL TRAINING

Detailed LiftMaster product training is available.
For more information, contact

Phone

877-TRAIN50 (872-4650)

Email

TrainingAcademy@LiftMaster.com

Online

LiftmasterTraining.com

LiftMaster®

Professional Products

845 Larch Avenue
Elmhurst, IL 60126
www.liftmaster.com

LiftMaster reserves the right to make design or
specification changes without notice.

LMCDOTSG 05/14 Printed in U.S.A.